

Appendix 14C
Forecast Traffic Flow Diagrams

[THIS PAGE INTENTIONALLY LEFT BLANK]

Low Growth

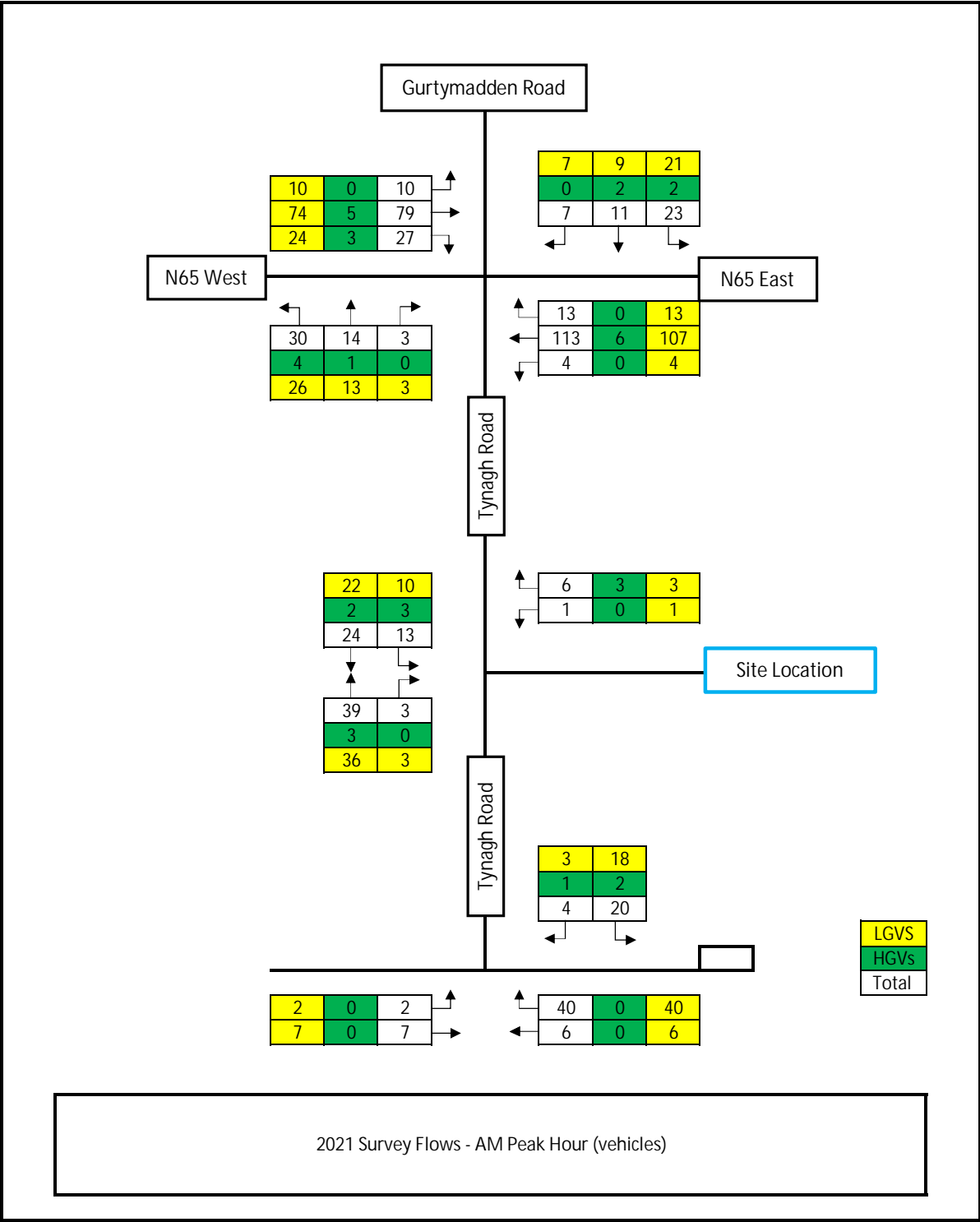

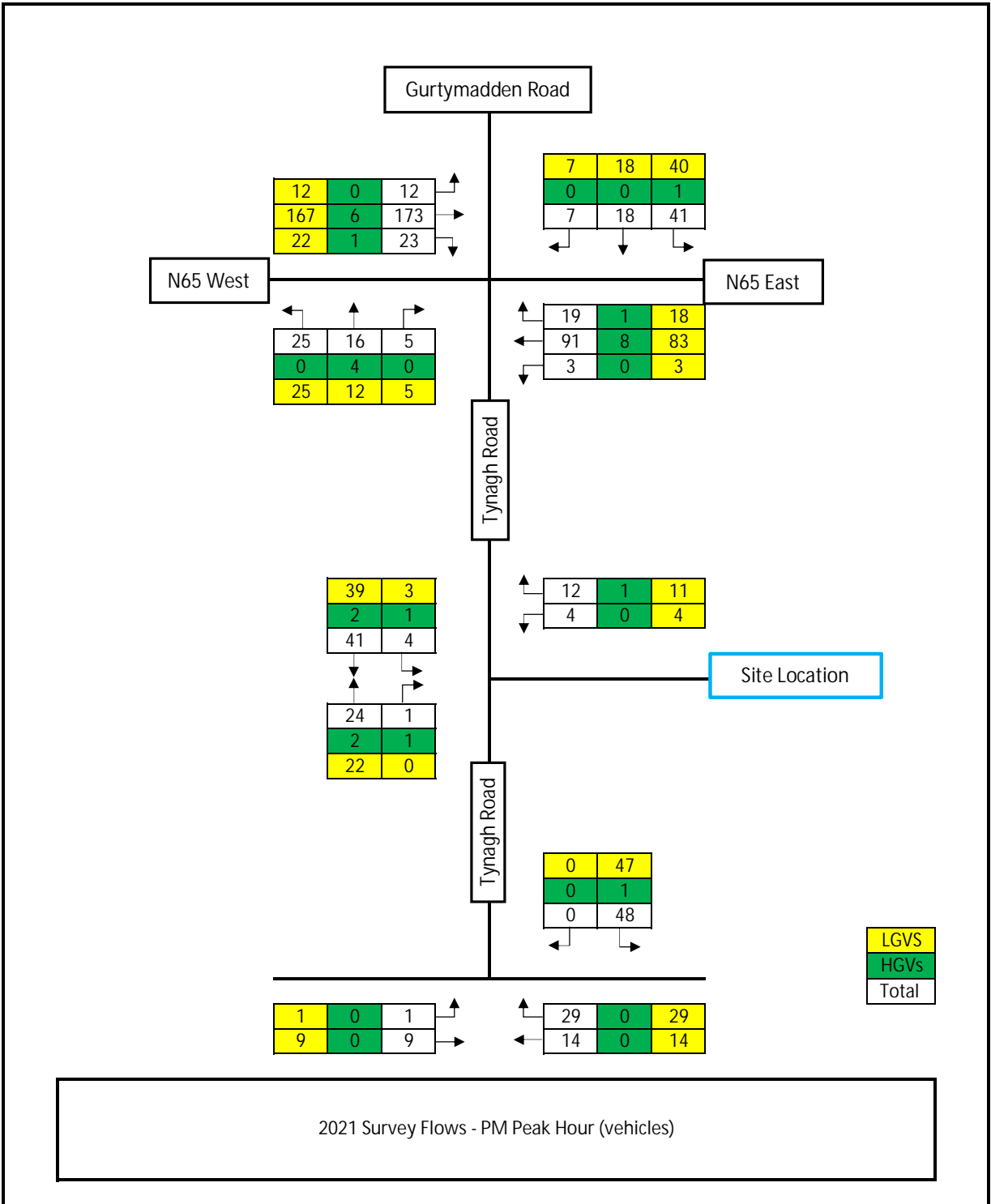

Gurty Madden Road

N65 West

N65 East

Tynagh Road

Tynagh Road

Site Location

LGVS
HGVs
Total

12	0	12
167	6	173
22	1	23

7	18	40
0	0	1
7	18	41

25	16	5
0	4	0
25	12	5

19	1	18
91	8	83
3	0	3

39	3
2	1
41	4

12	1	11
4	0	4

24	1
2	1
22	0

0	47
0	1
0	48

1	0	1
9	0	9

29	0	29
14	0	14

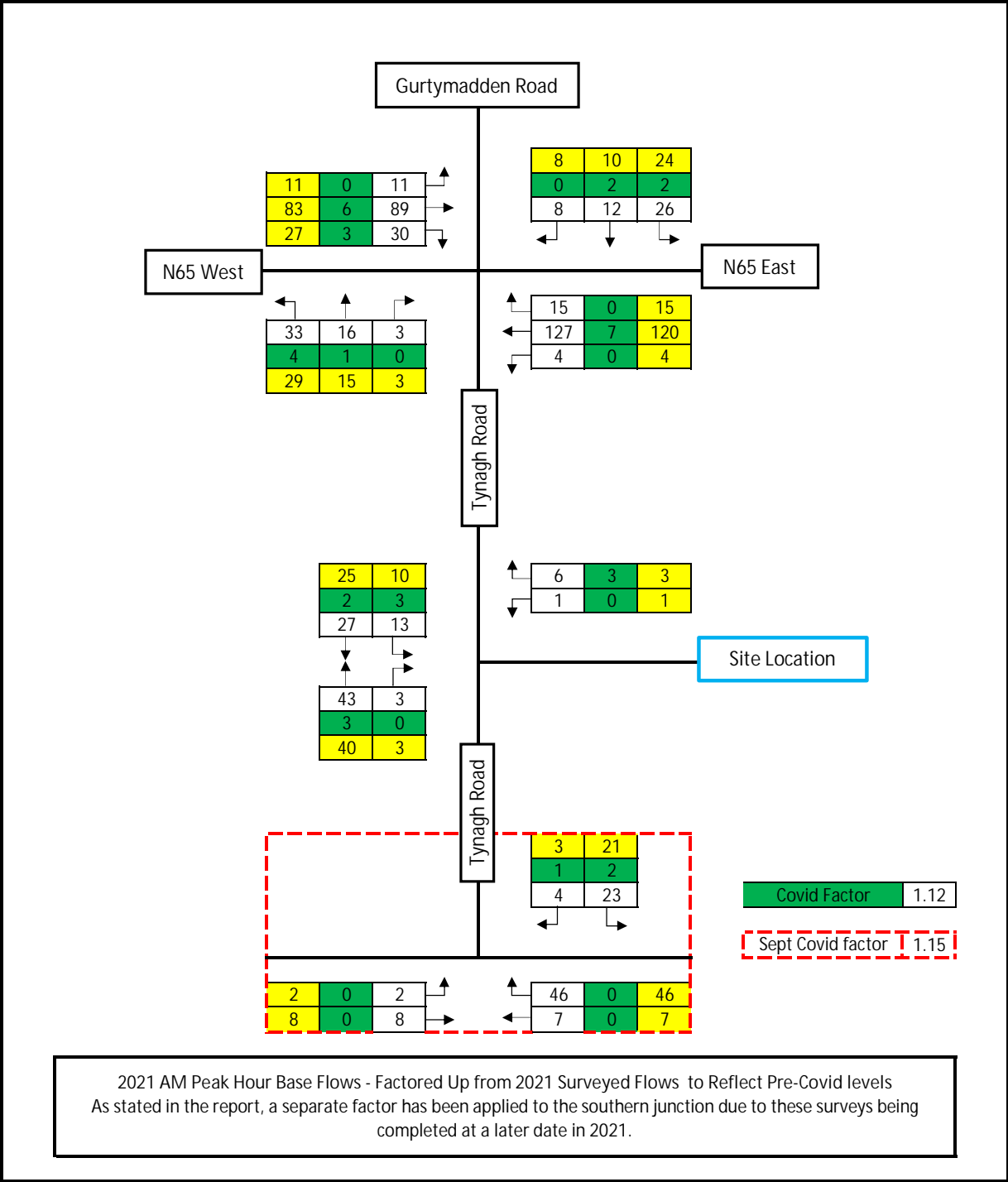

Gurty Madden Road

N65 West

N65 East

Tynagh Road

Tynagh Road

Site Location

11	0	11
83	6	89
27	3	30

8	10	24
0	2	2
8	12	26

33	16	3
4	1	0
29	15	3

15	0	15
127	7	120
4	0	4

25	10
2	3
27	13

6	3	3
1	0	1

43	3
3	0
40	3

3	21
1	2
4	23

Covid Factor 1.12

Sept Covid factor 1.15

2	0	2
8	0	8

46	0	46
7	0	7

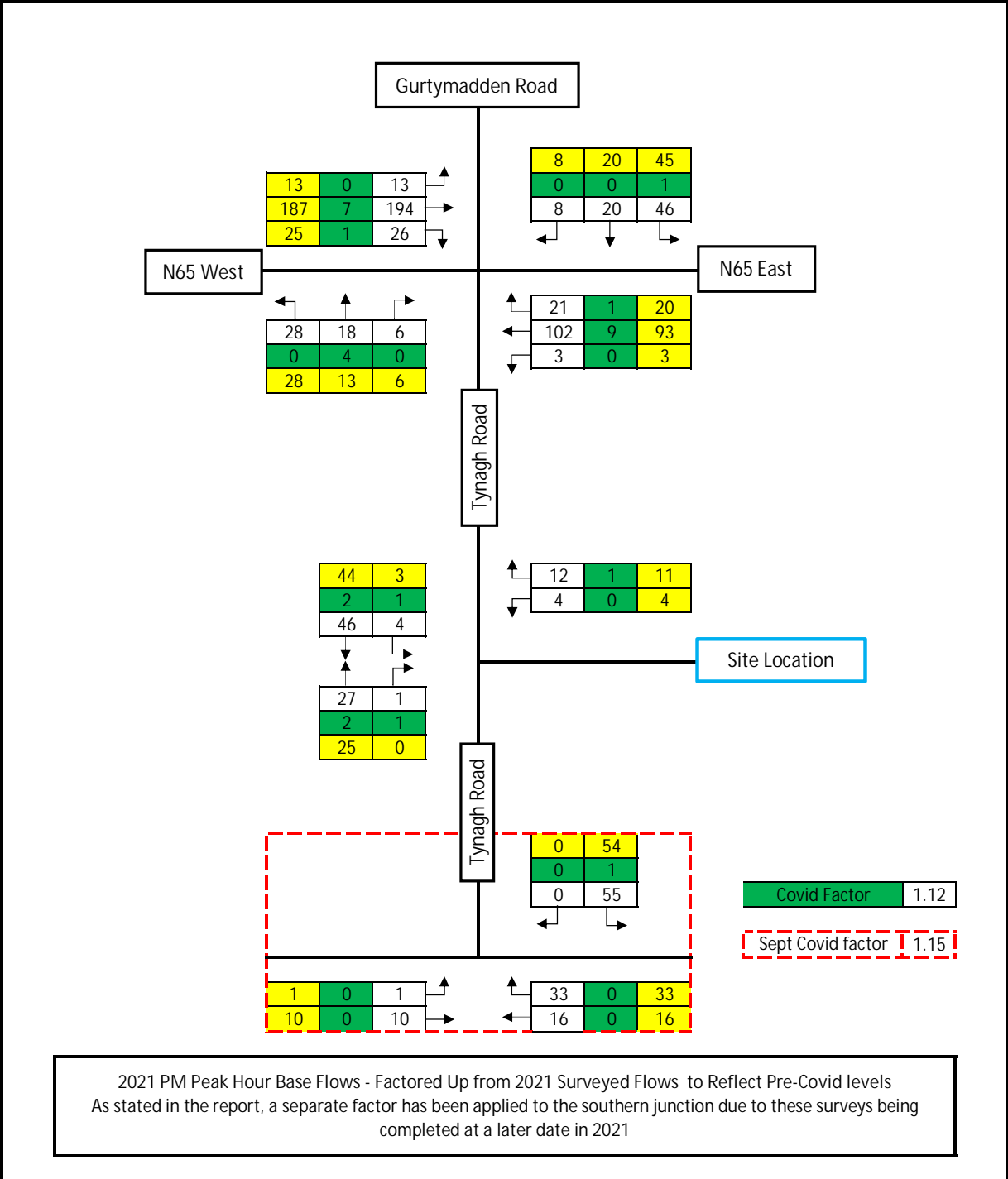

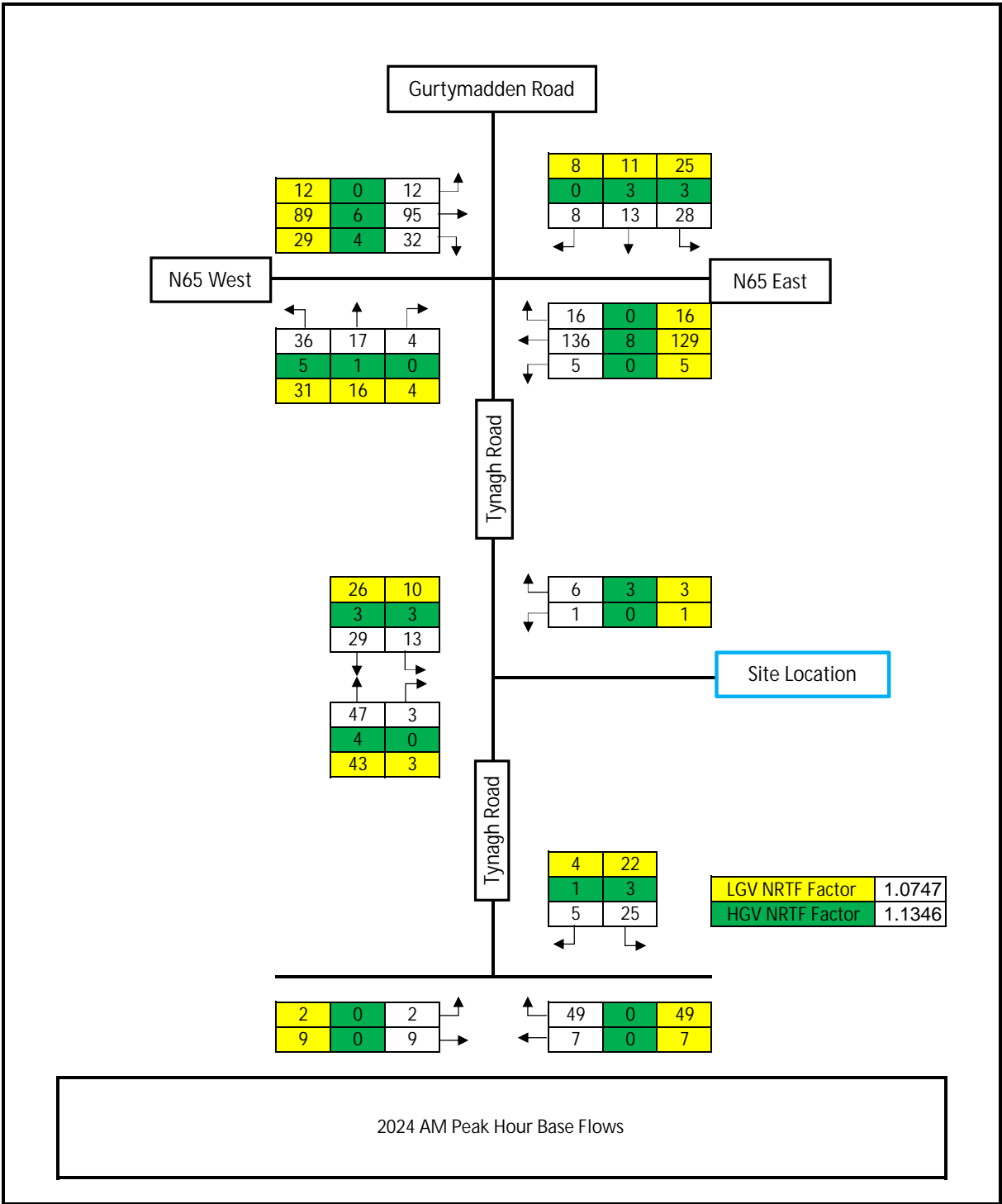

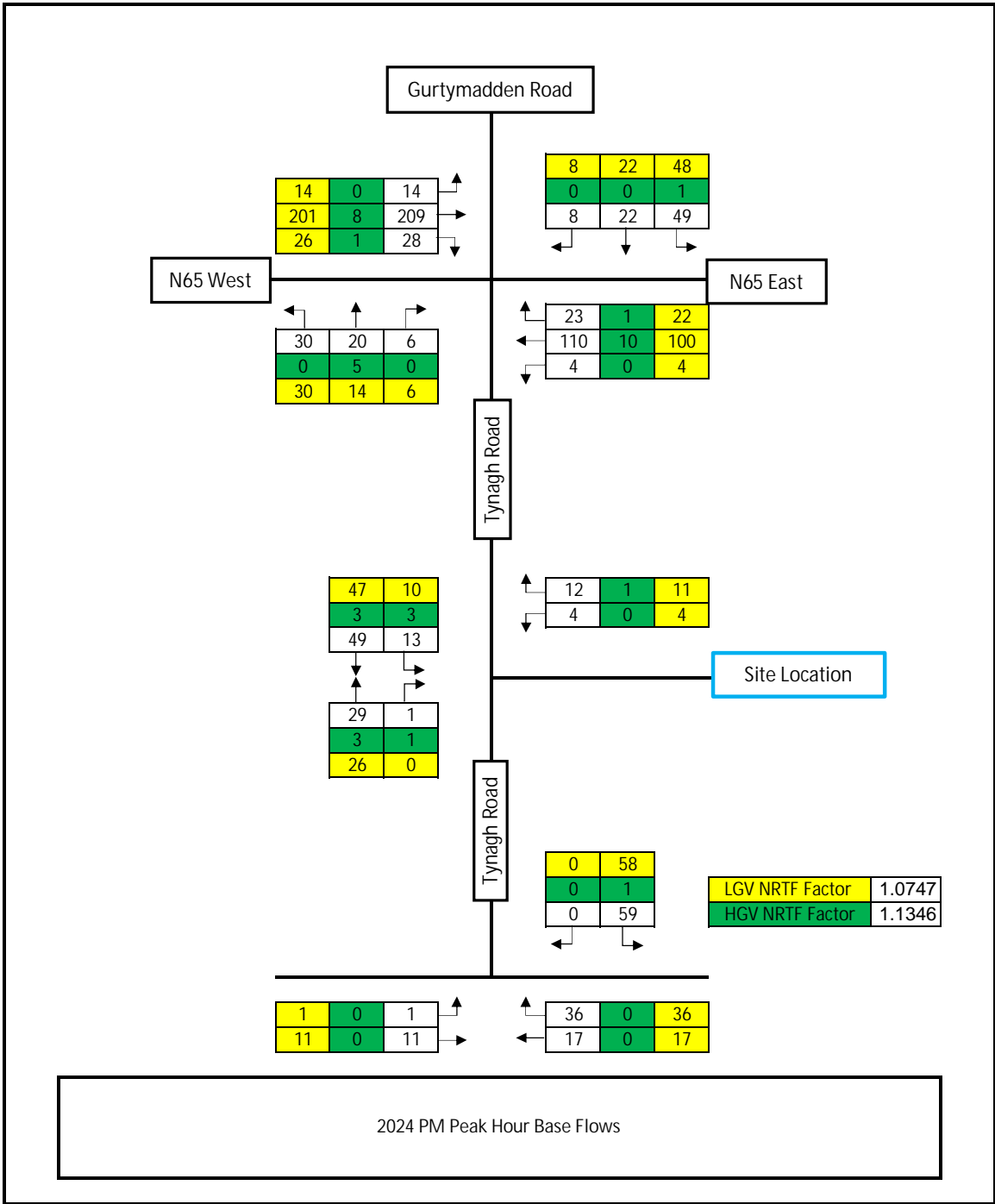

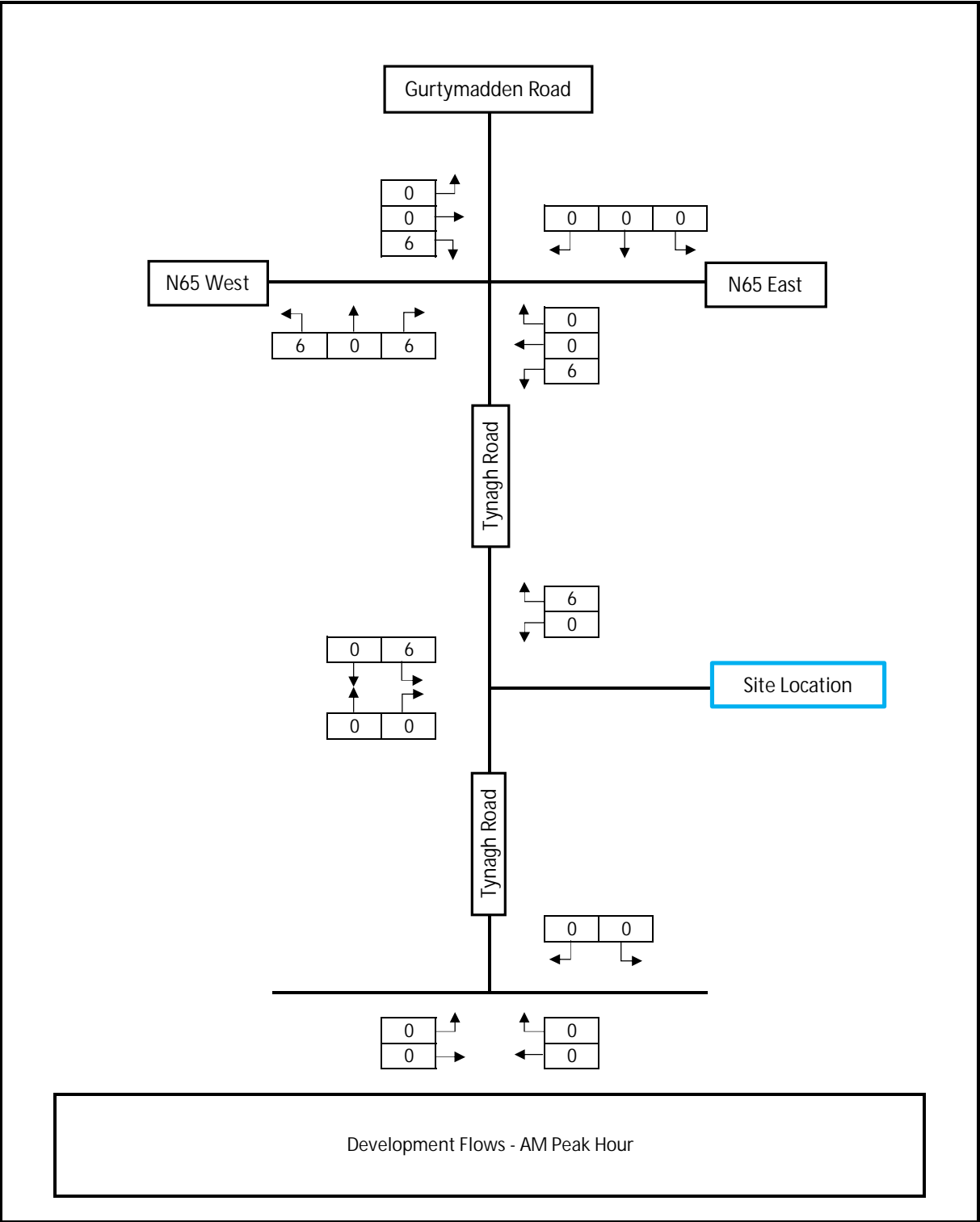

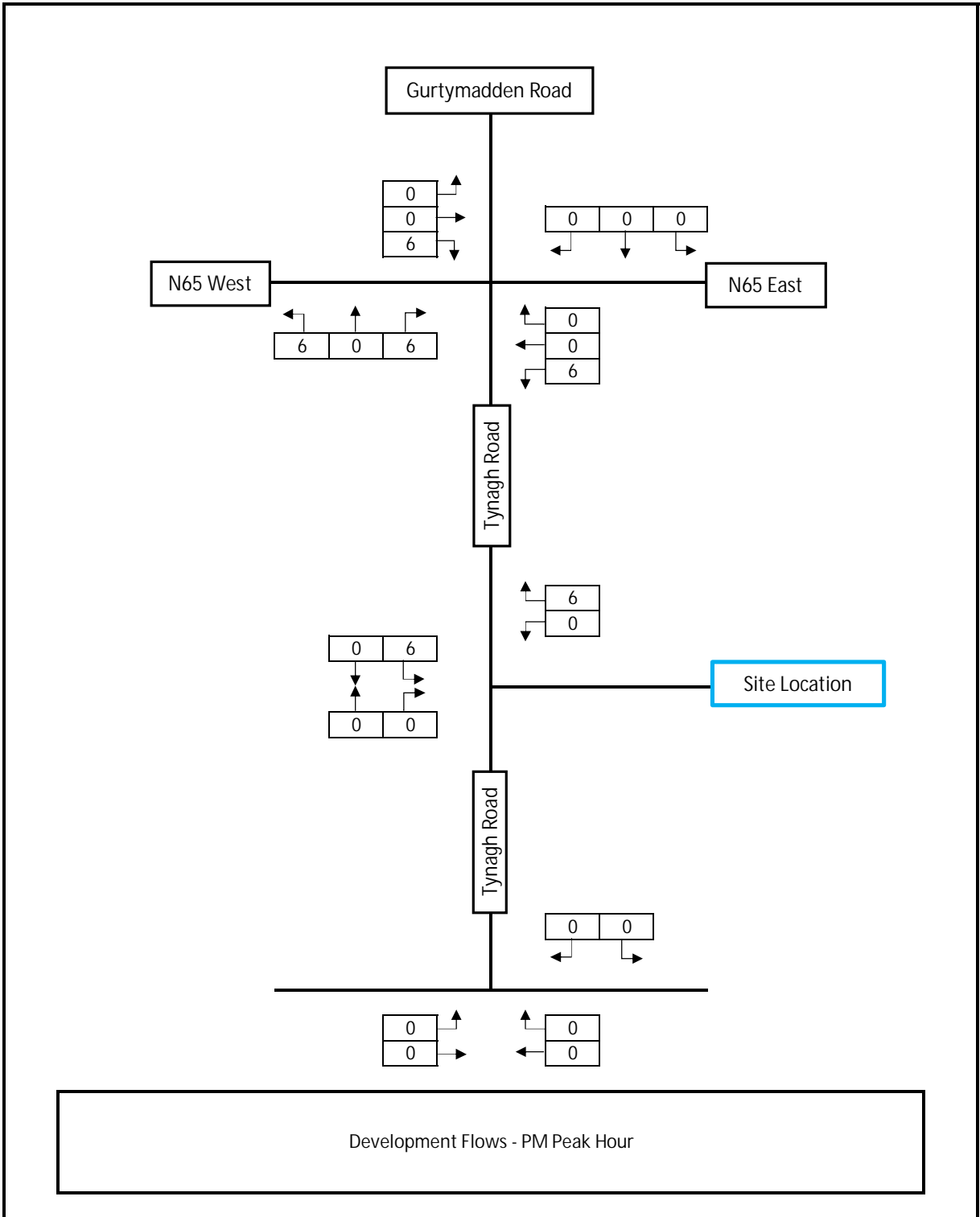

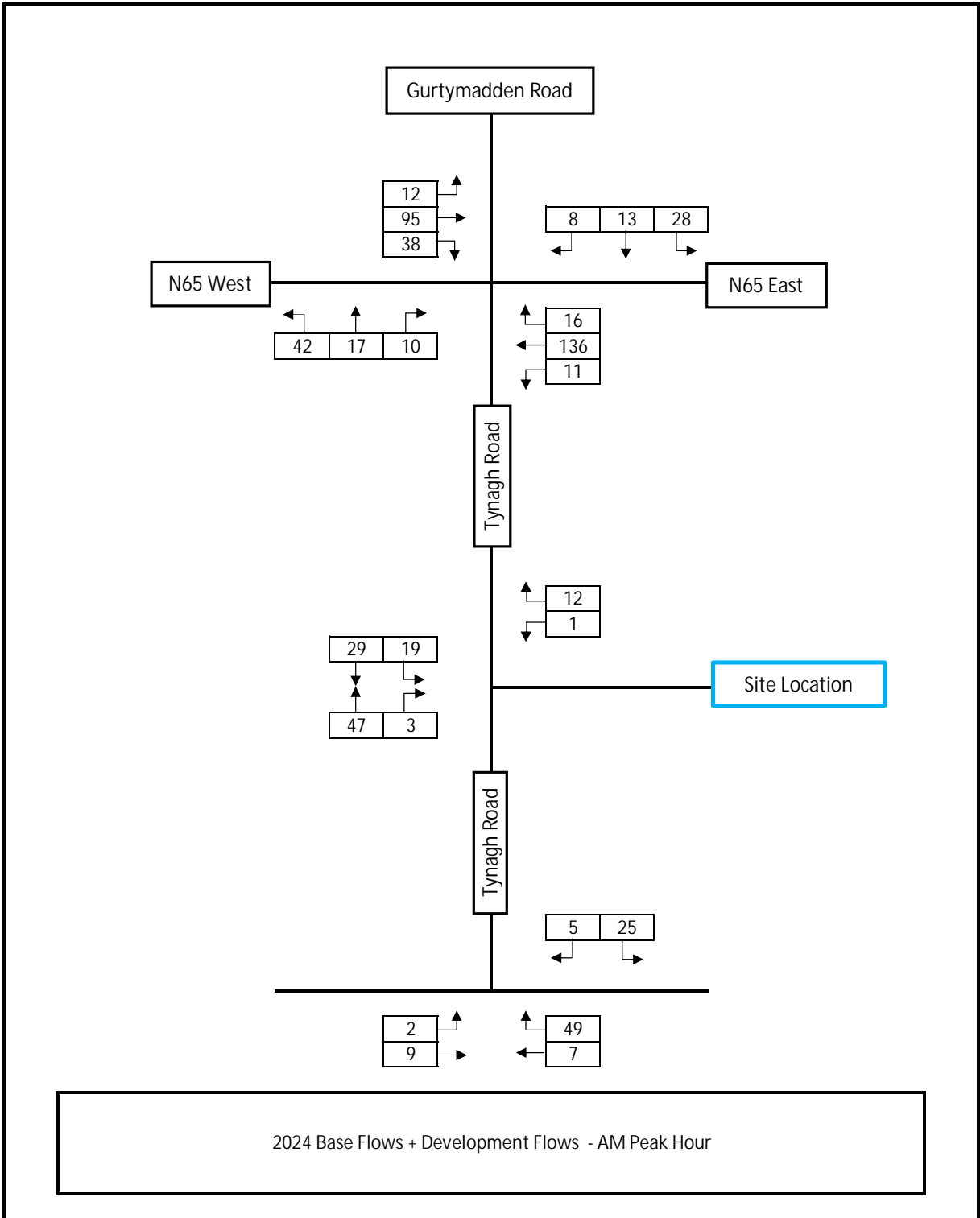

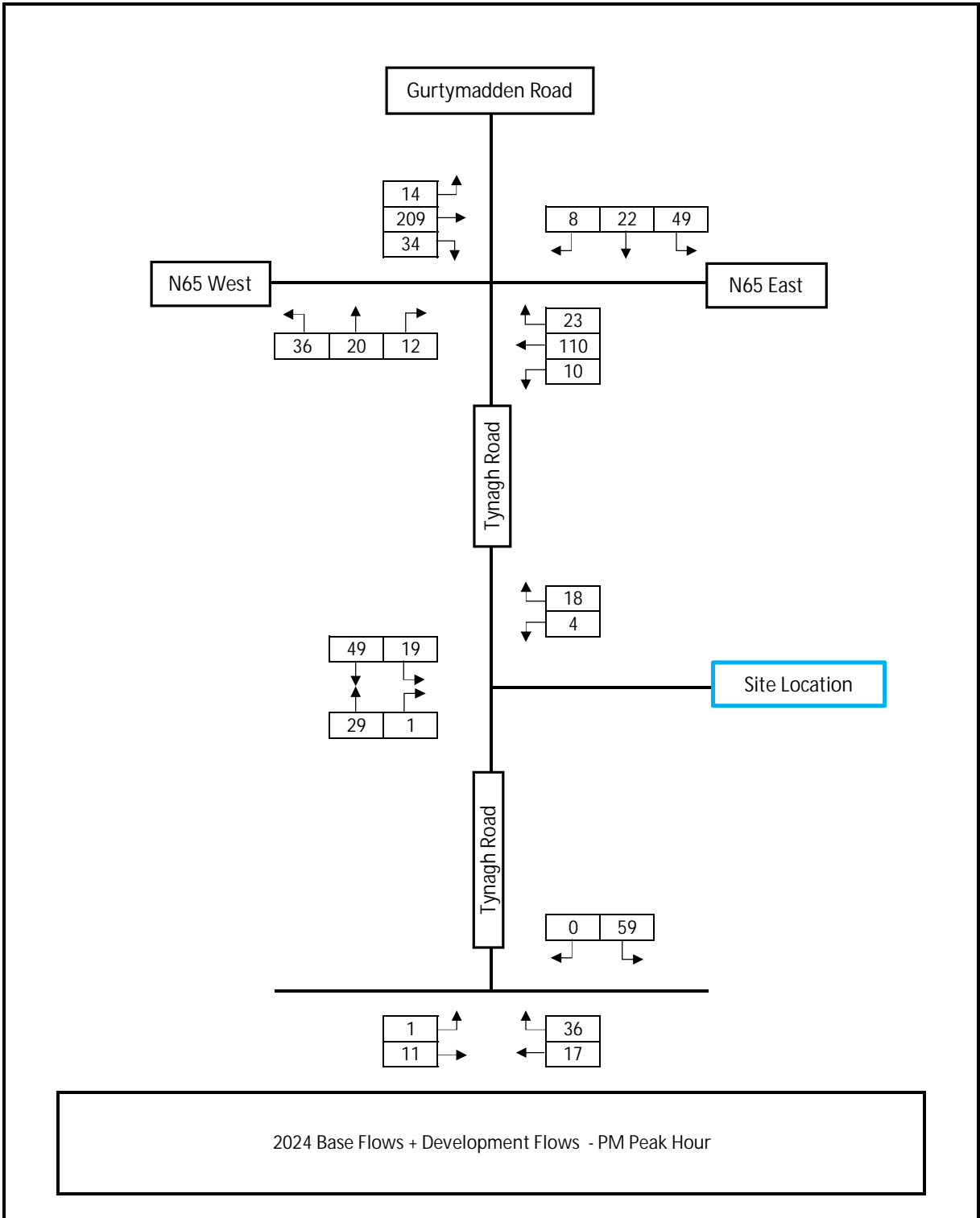

Central Growth

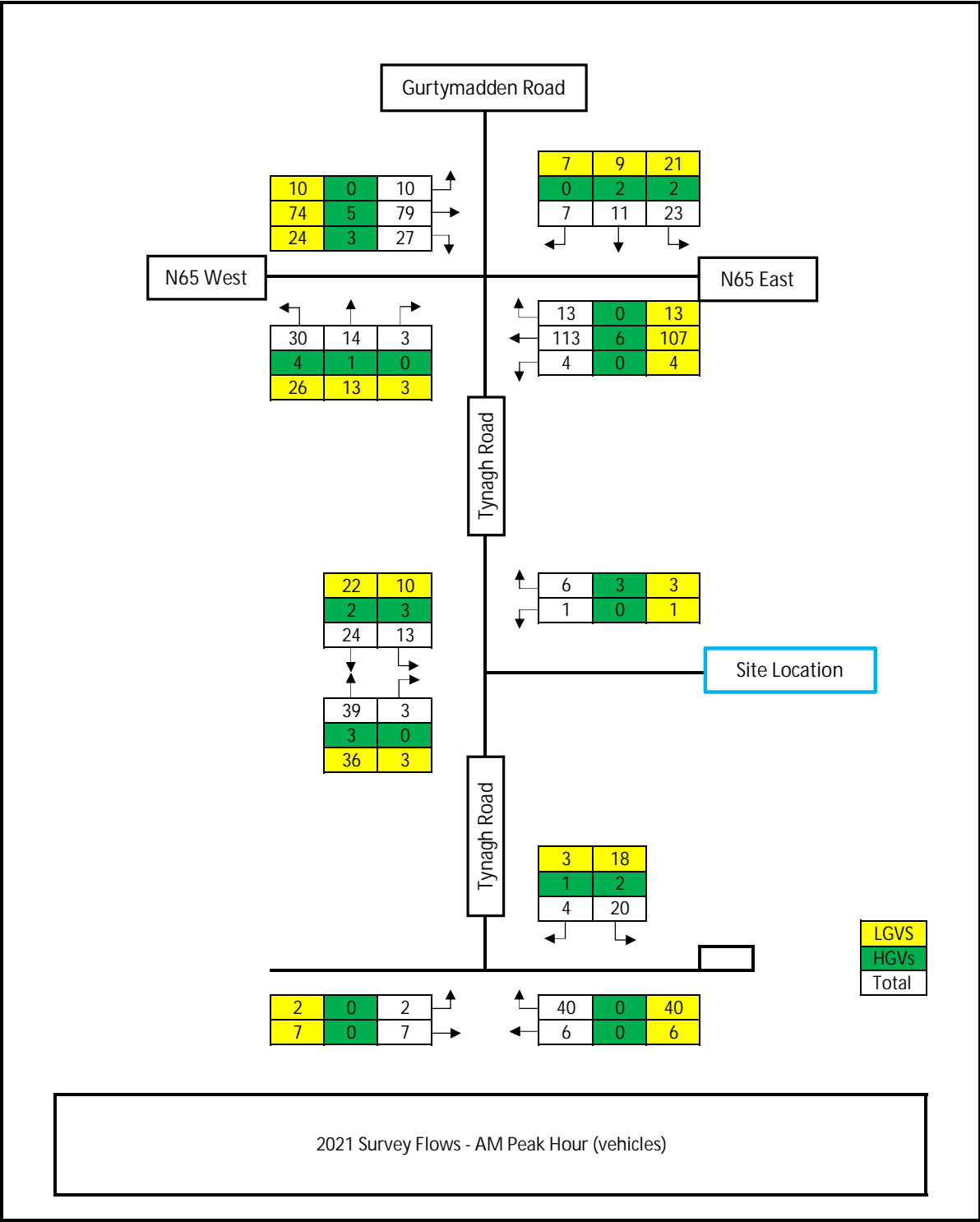

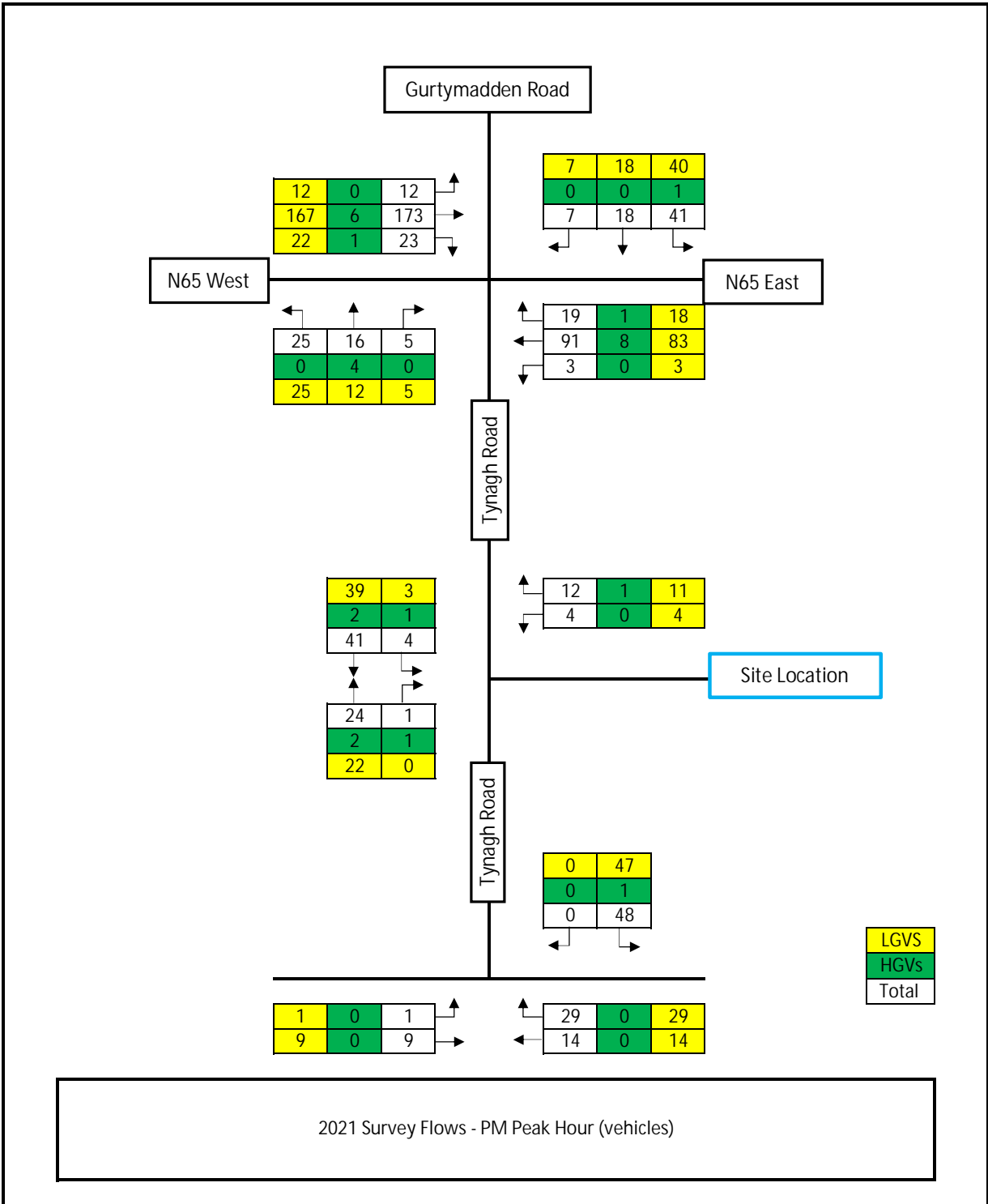

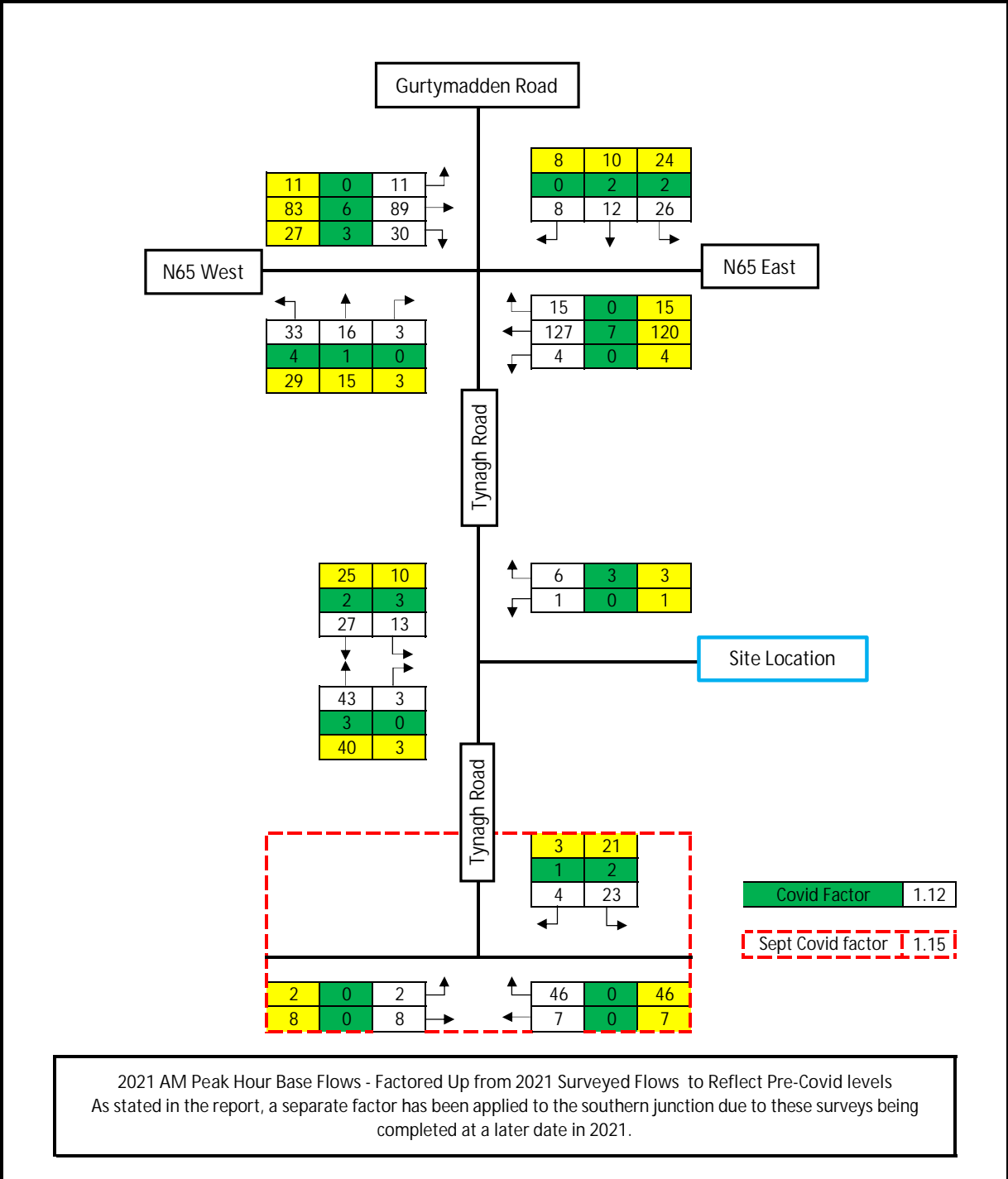

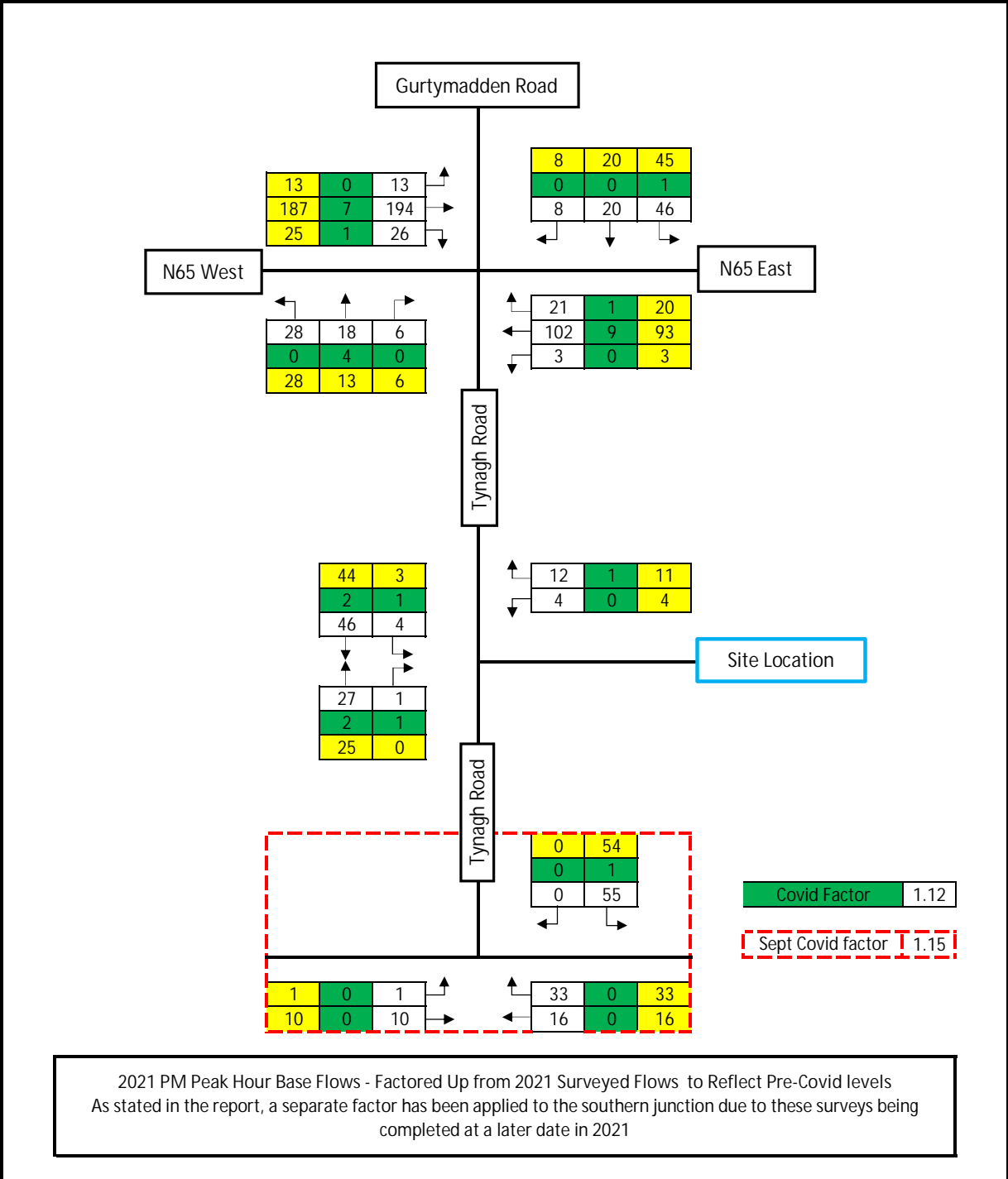

2021 PM Peak Hour Base Flows - Factored Up from 2021 Surveyed Flows to Reflect Pre-Covid levels
 As stated in the report, a separate factor has been applied to the southern junction due to these surveys being completed at a later date in 2021

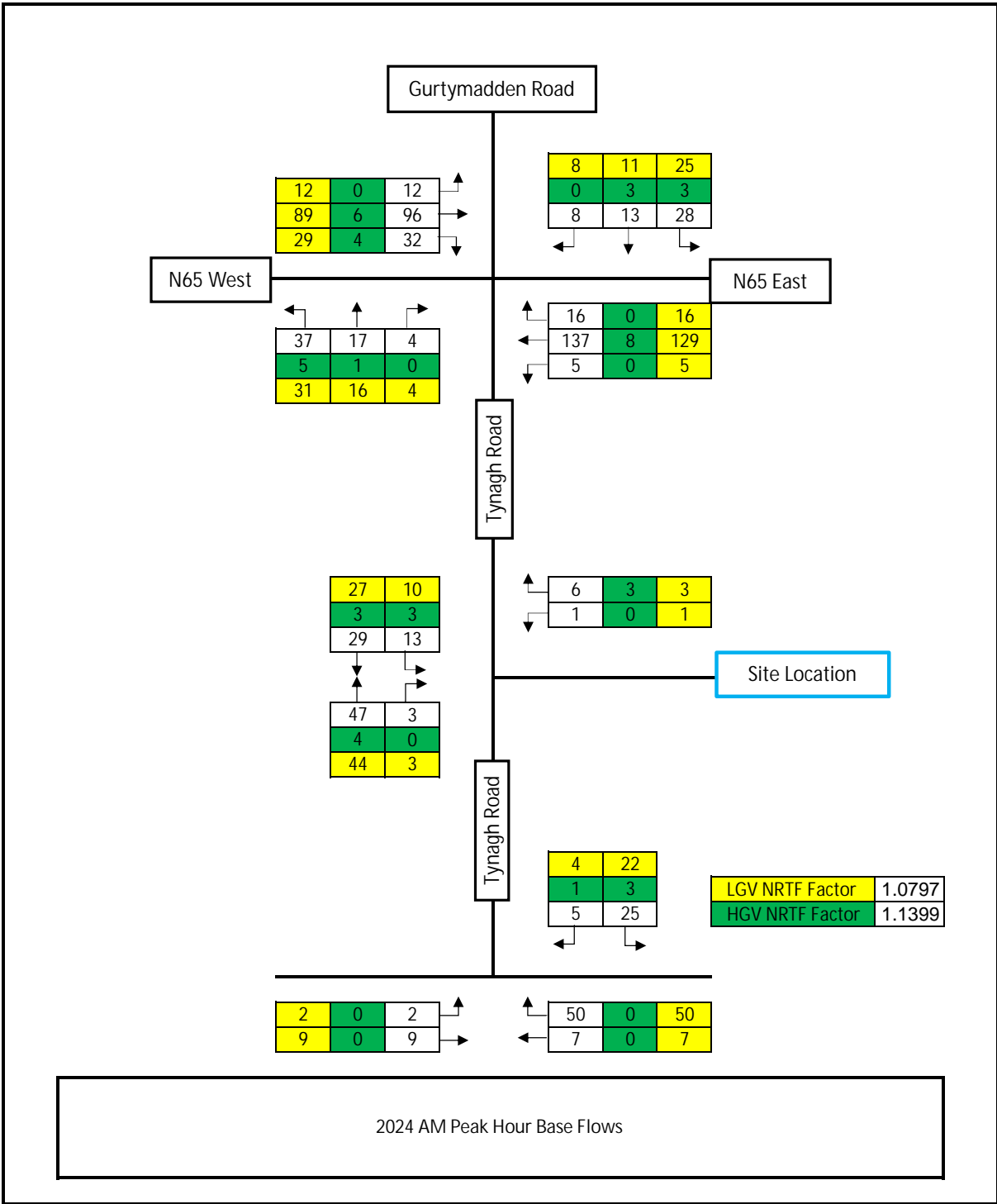

Gurty Madden Road

N65 West

N65 East

Tynagh Road

Tynagh Road

Site Location

LGV NRTF Factor	1.0797
HGV NRTF Factor	1.1399

12	0	12
89	6	96
29	4	32

8	11	25
0	3	3
8	13	28

37	17	4
5	1	0
31	16	4

16	0	16
137	8	129
5	0	5

27	10
3	3
29	13

6	3	3
1	0	1

47	3
4	0
44	3

4	22
1	3
5	25

2	0	2
9	0	9

50	0	50
7	0	7

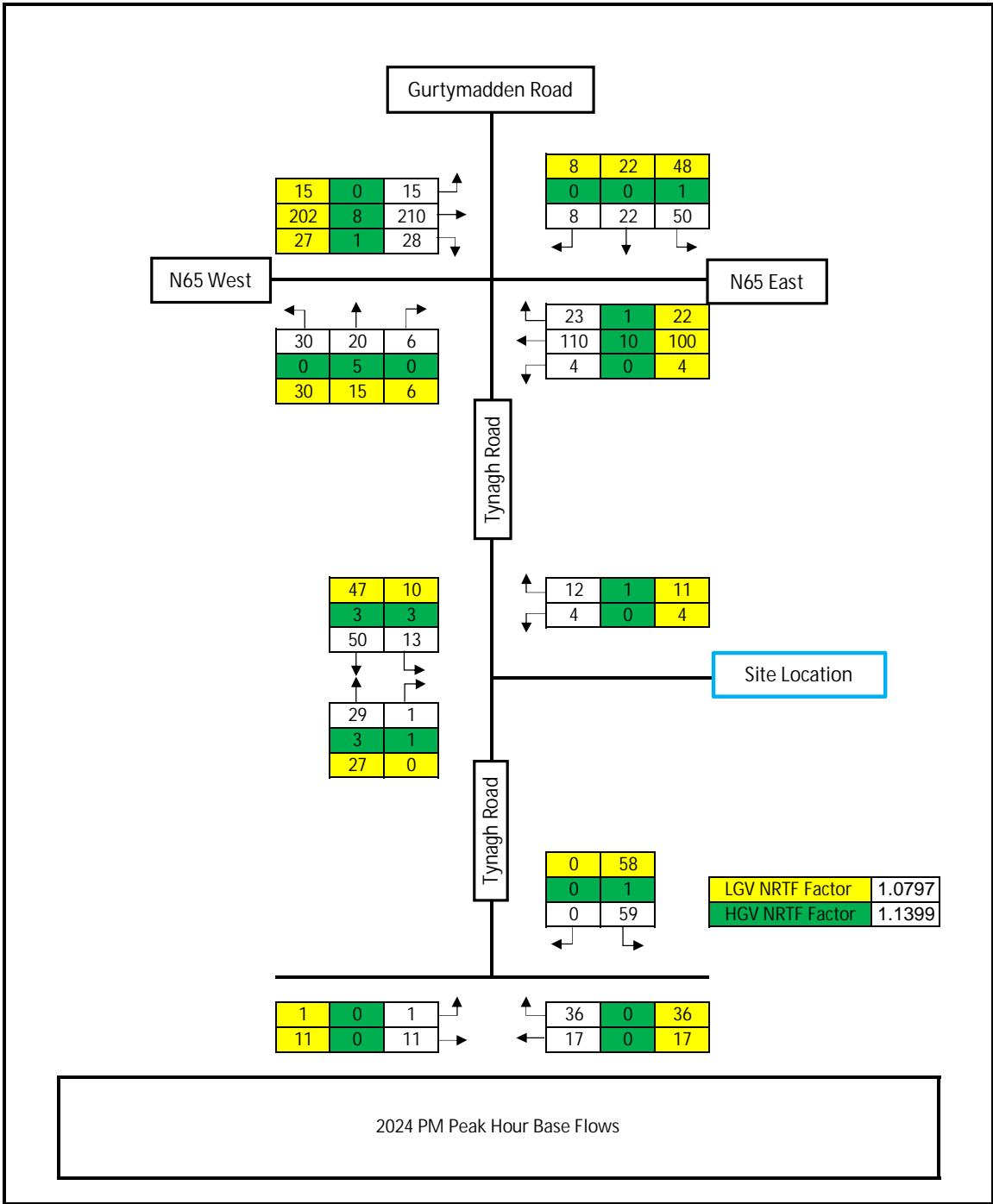

Gurty Madden Road

N65 West

N65 East

Tynagh Road

Tynagh Road

Site Location

15	0	15
202	8	210
27	1	28

8	22	48
0	0	1
8	22	50

30	20	6
0	5	0
30	15	6

23	1	22
110	10	100
4	0	4

47	10
3	3
50	13

12	1	11
4	0	4

29	1
3	1
27	0

0	58
0	1
0	59

LGV NRTF Factor	1.0797
HGV NRTF Factor	1.1399

1	0	1
11	0	11

36	0	36
17	0	17

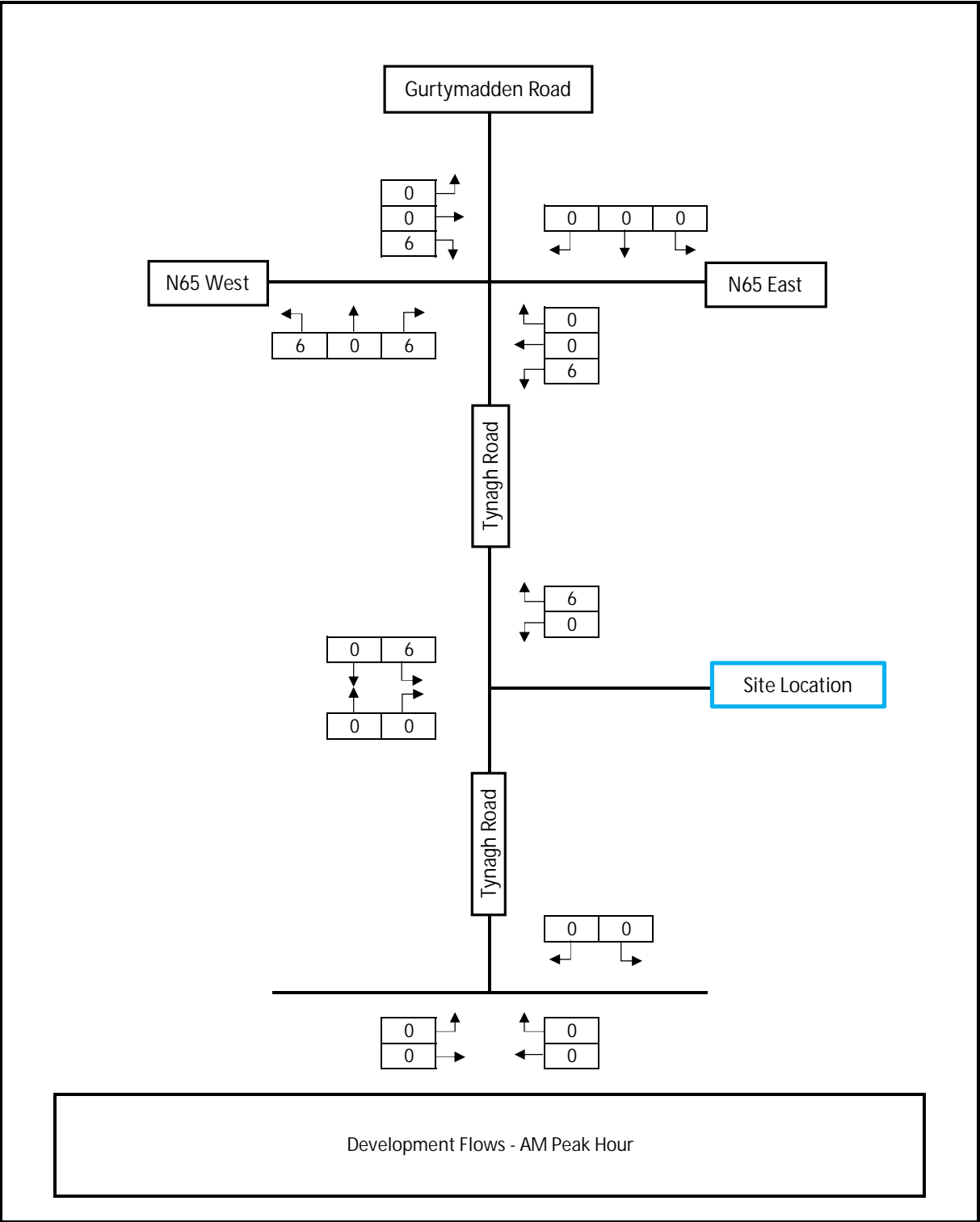

Development Flows - AM Peak Hour

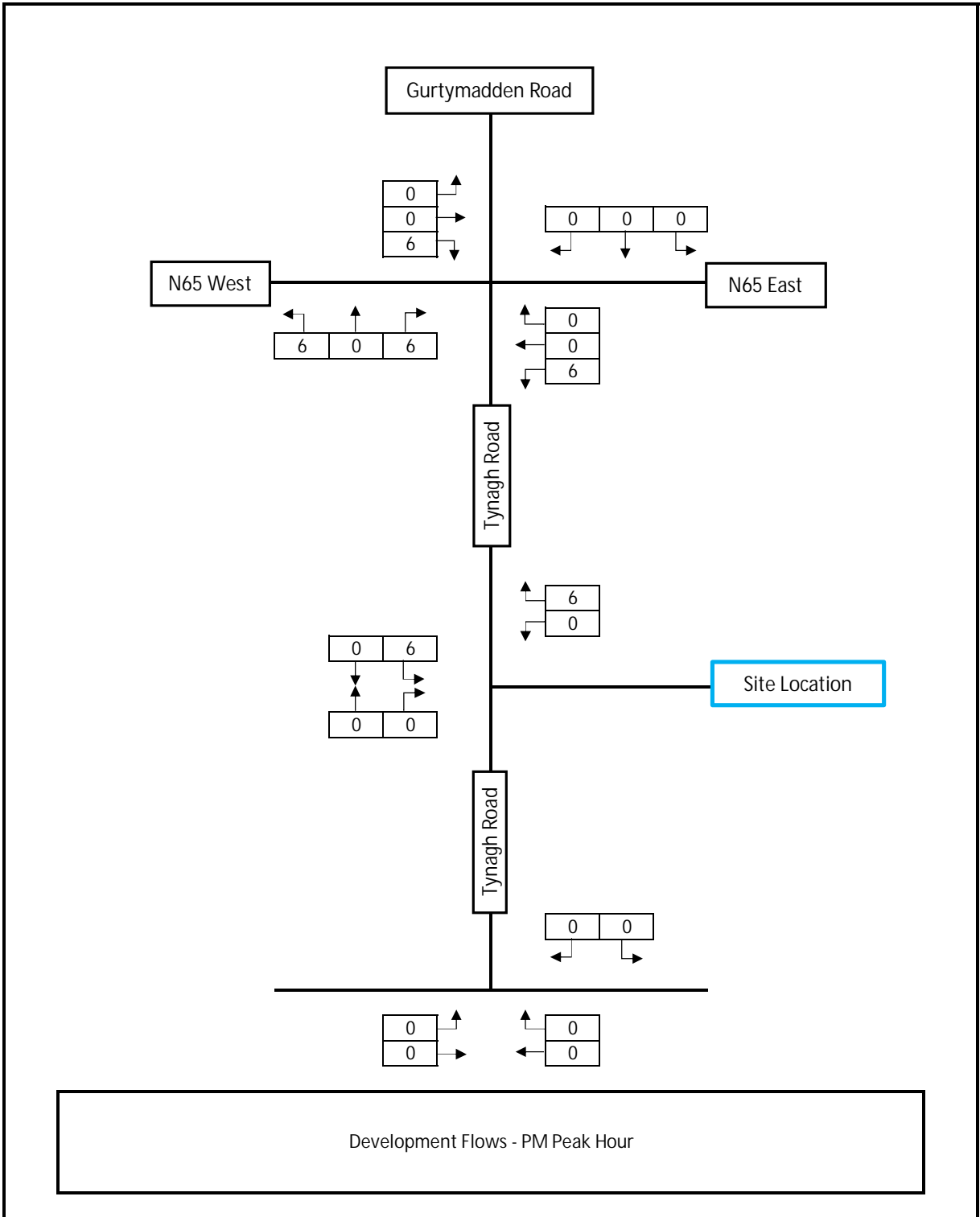

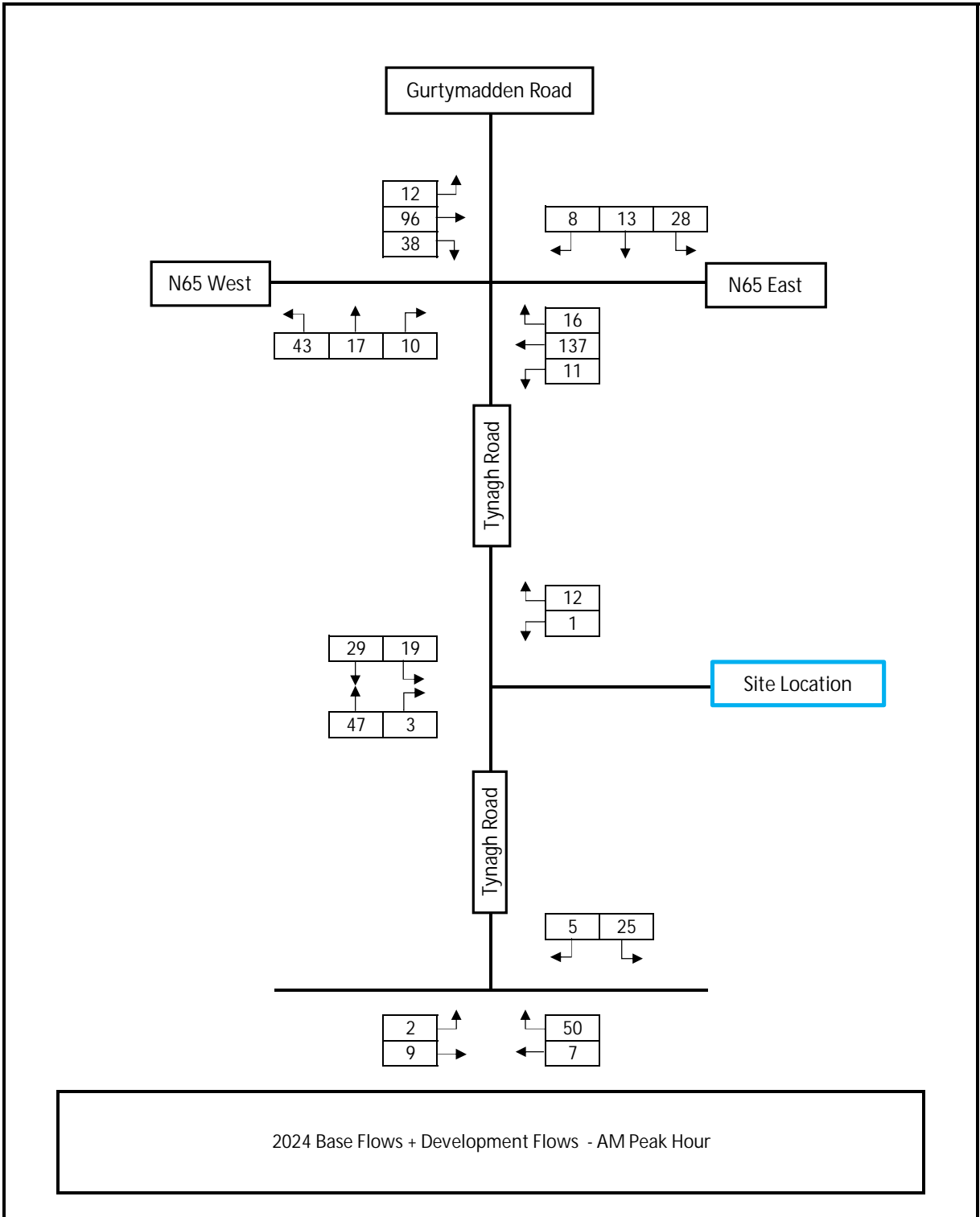

Gurty Madden Road

12	↑
96	→
38	↓

8	←
13	↓
28	→

N65 West

43	←
17	↑
10	→

N65 East

16	↑
137	←
11	↓

Tynagh Road

12	↑
1	↓

29	←
19	→

47	↑
3	→

Site Location

Tynagh Road

5	←
25	→

2	↑
9	→

50	↑
7	←

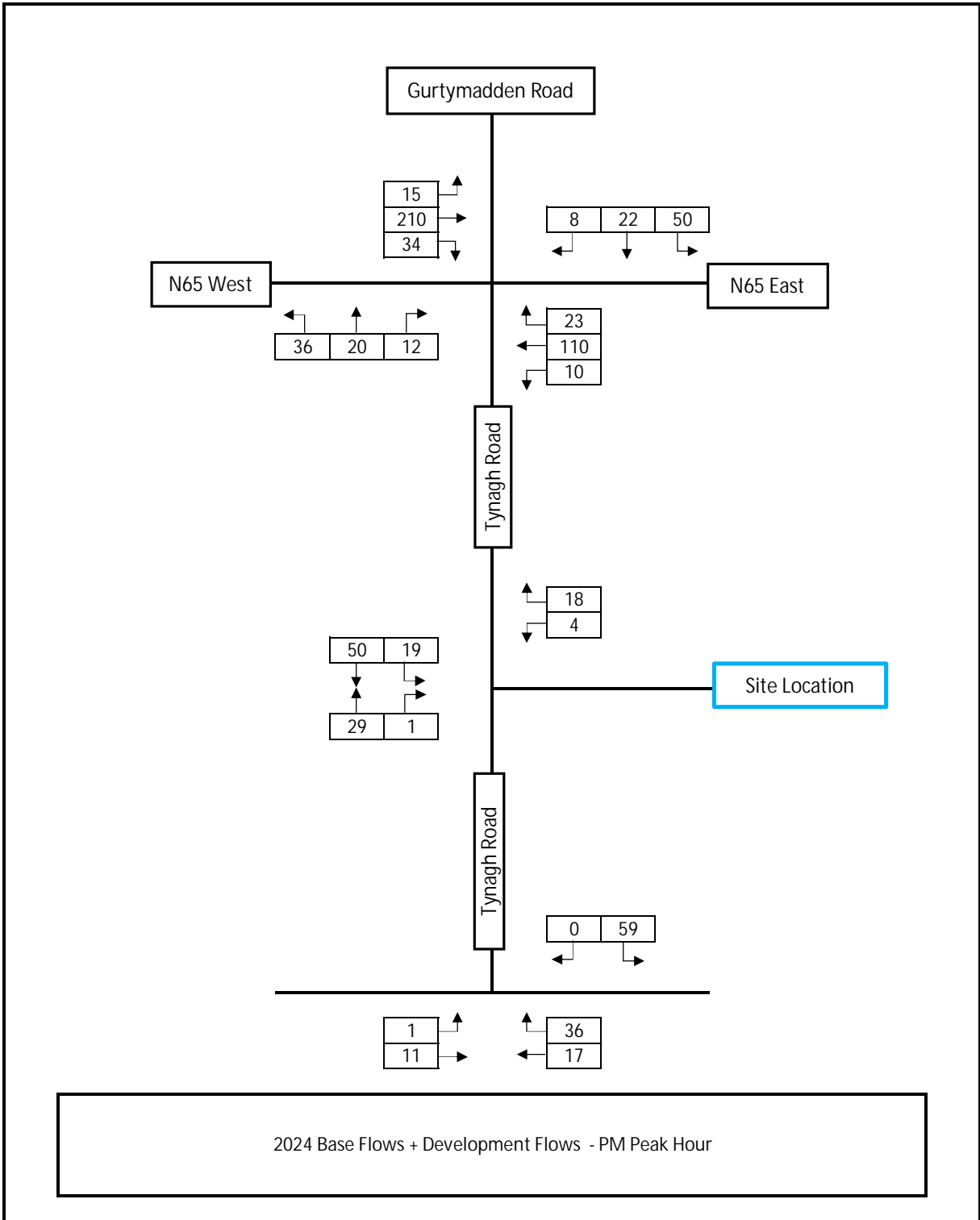

High Growth

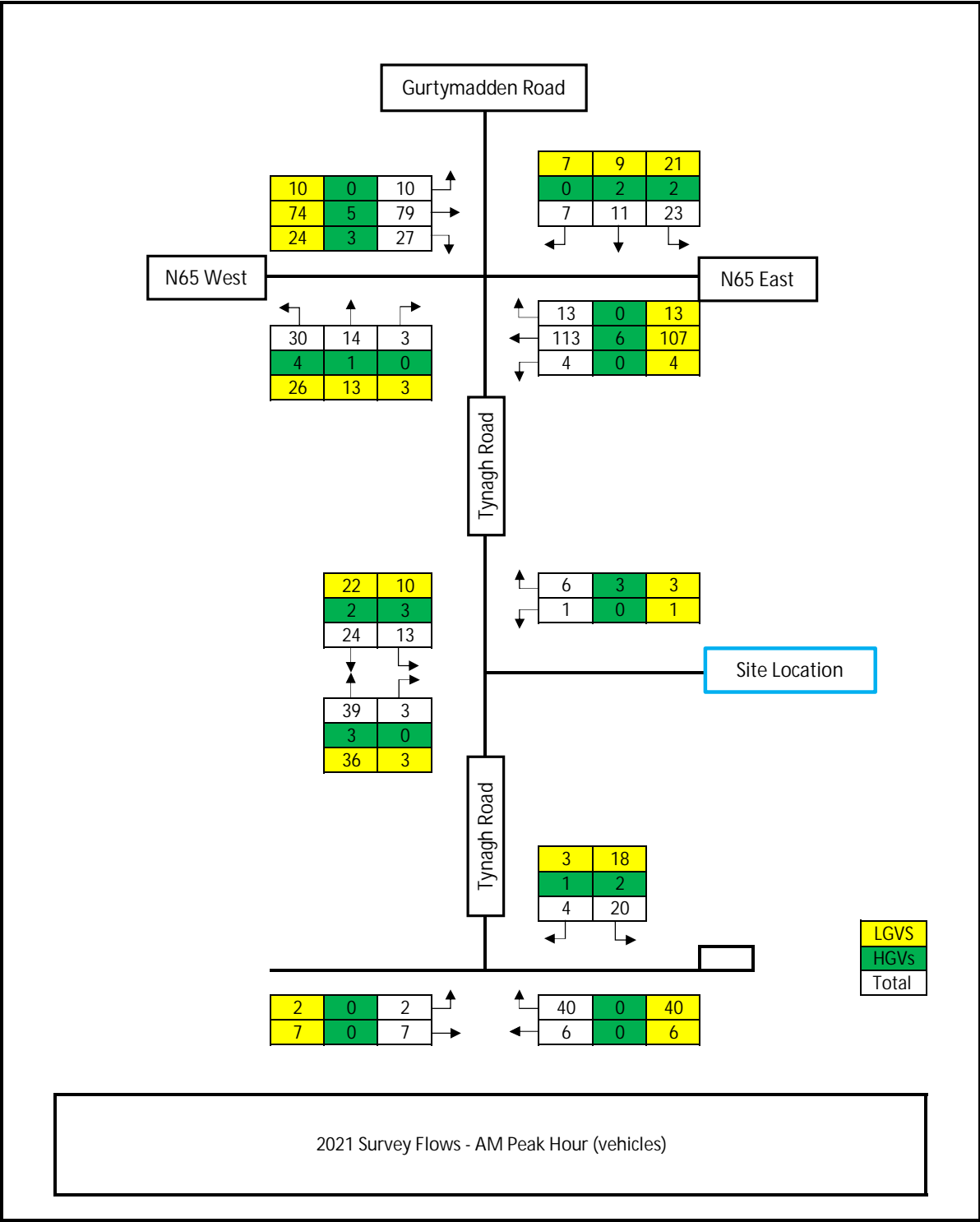

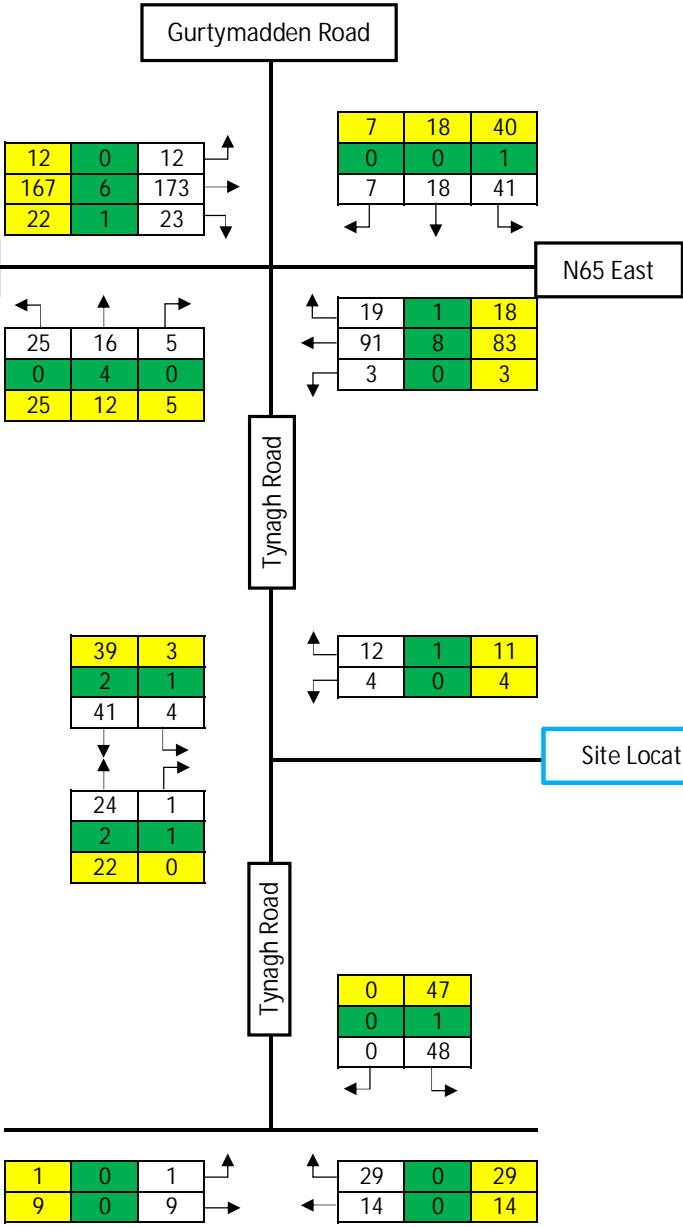
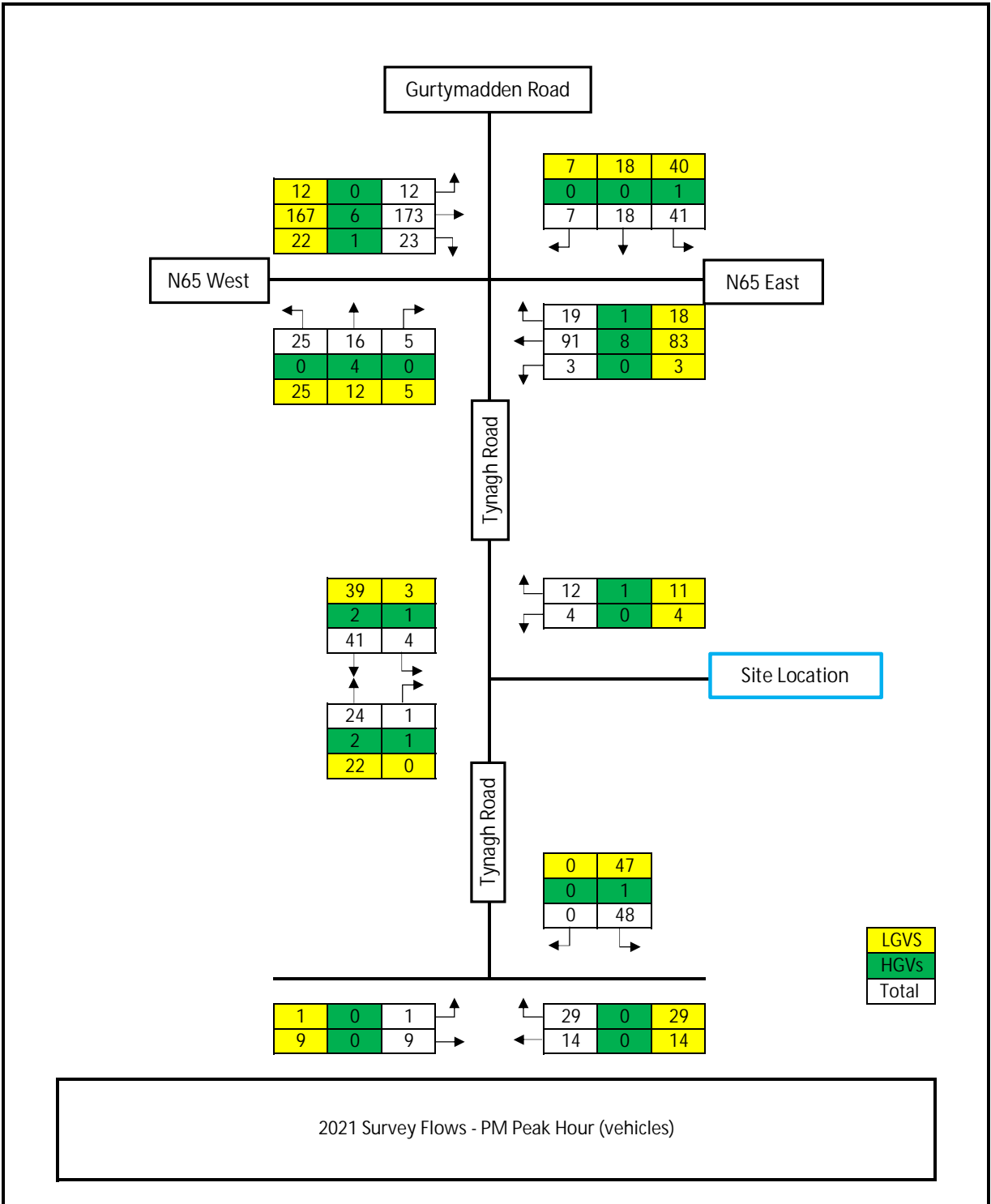

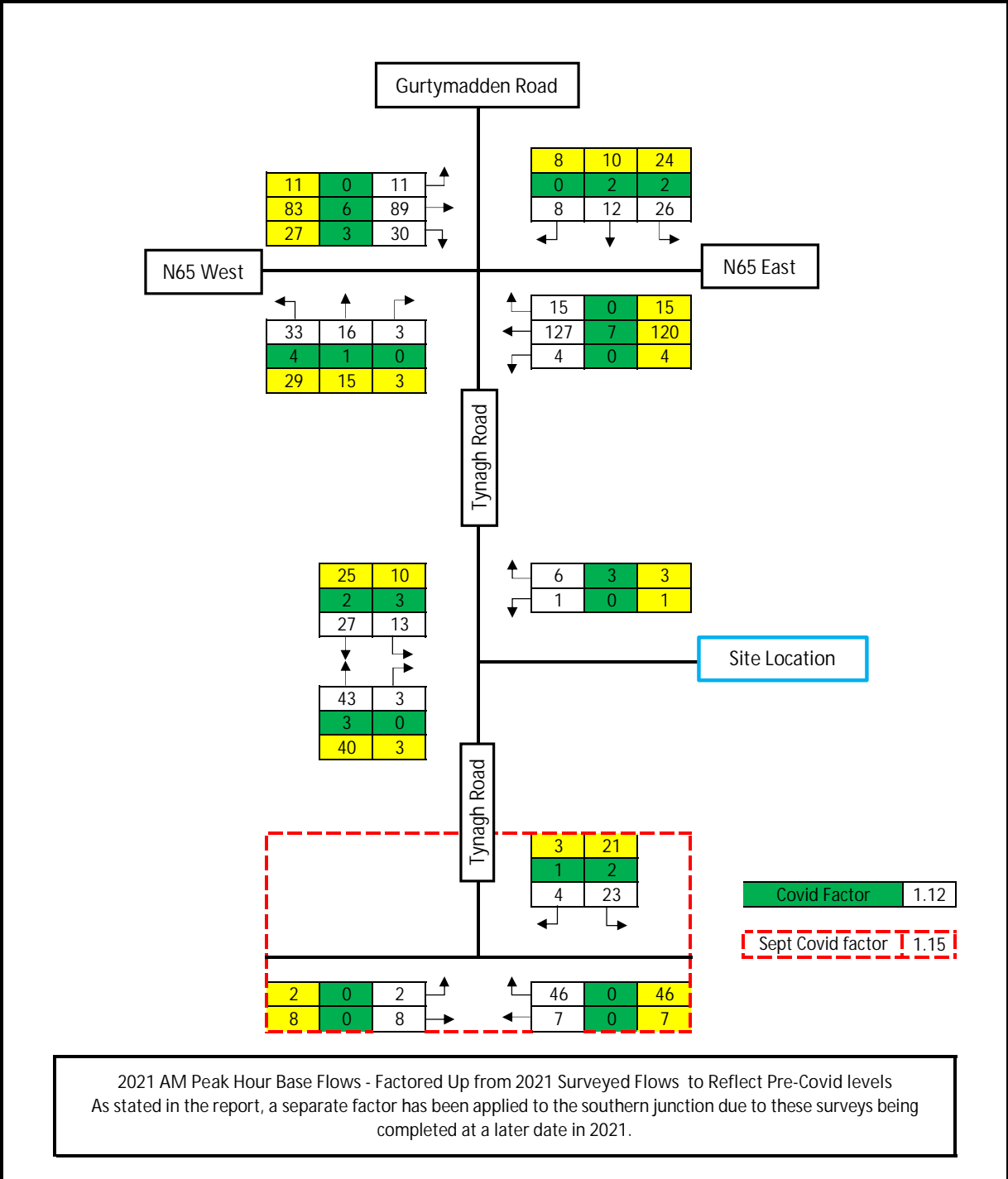

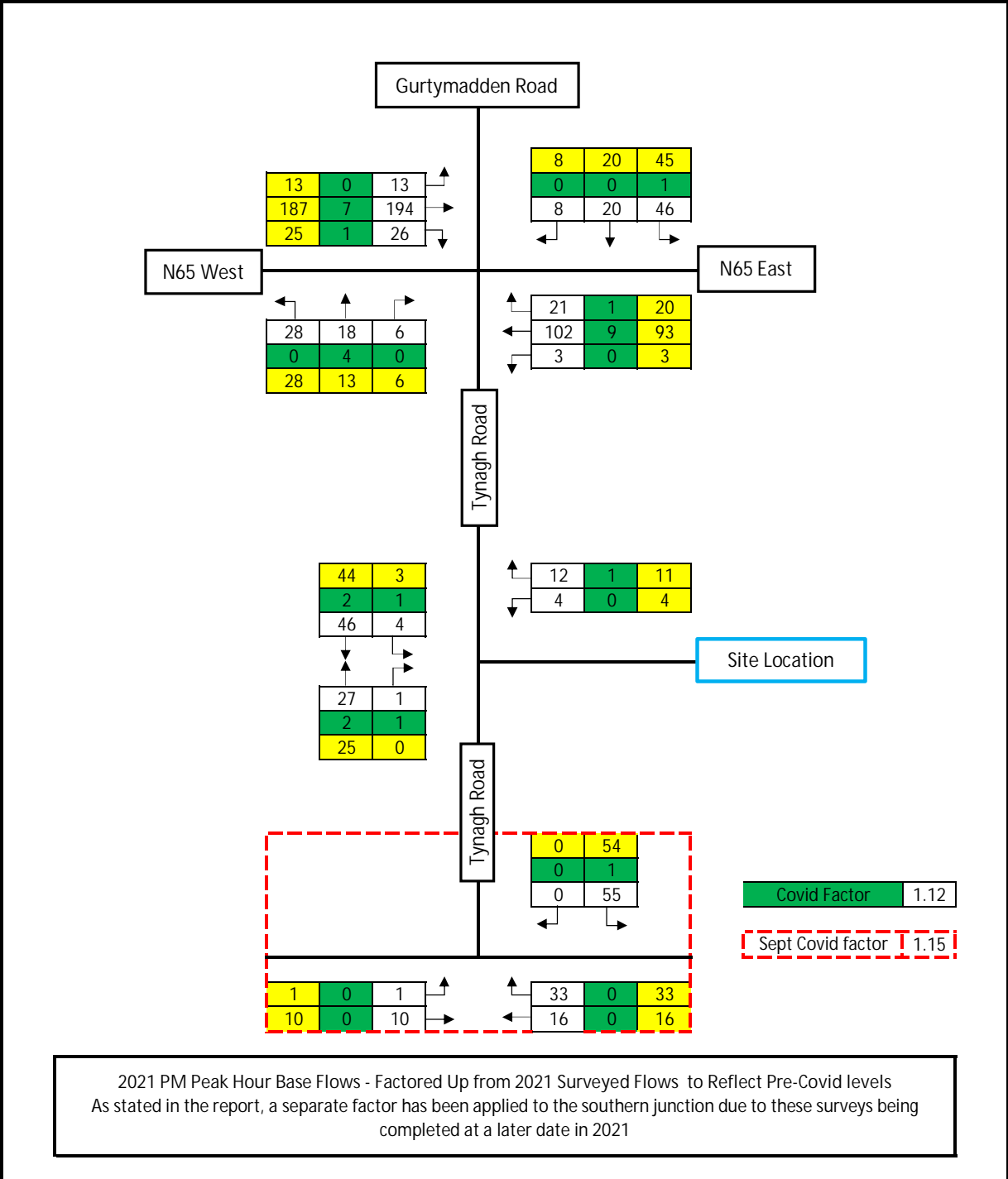

Gurty Madden Road

N65 West

N65 East

Tynagh Road

Site Location

Tynagh Road

13	0	13
187	7	194
25	1	26

8	20	45
0	0	1
8	20	46

28	18	6
0	4	0
28	13	6

21	1	20
102	9	93
3	0	3

44	3
2	1
46	4

12	1	11
4	0	4

27	1
2	1
25	0

0	54
0	1
0	55

Covid Factor 1.12

Sept Covid factor 1.15

1	0	1
10	0	10

33	0	33
16	0	16

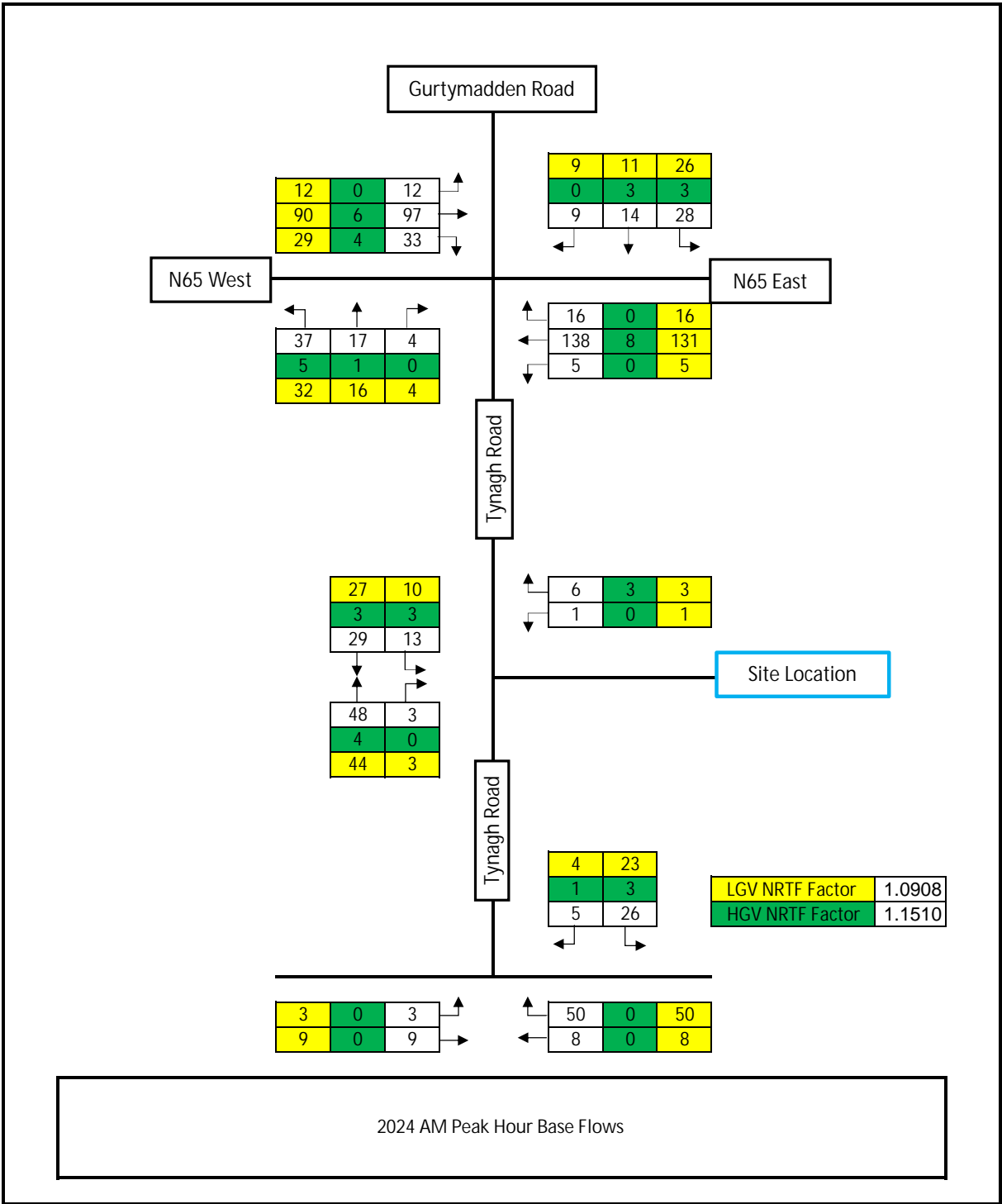

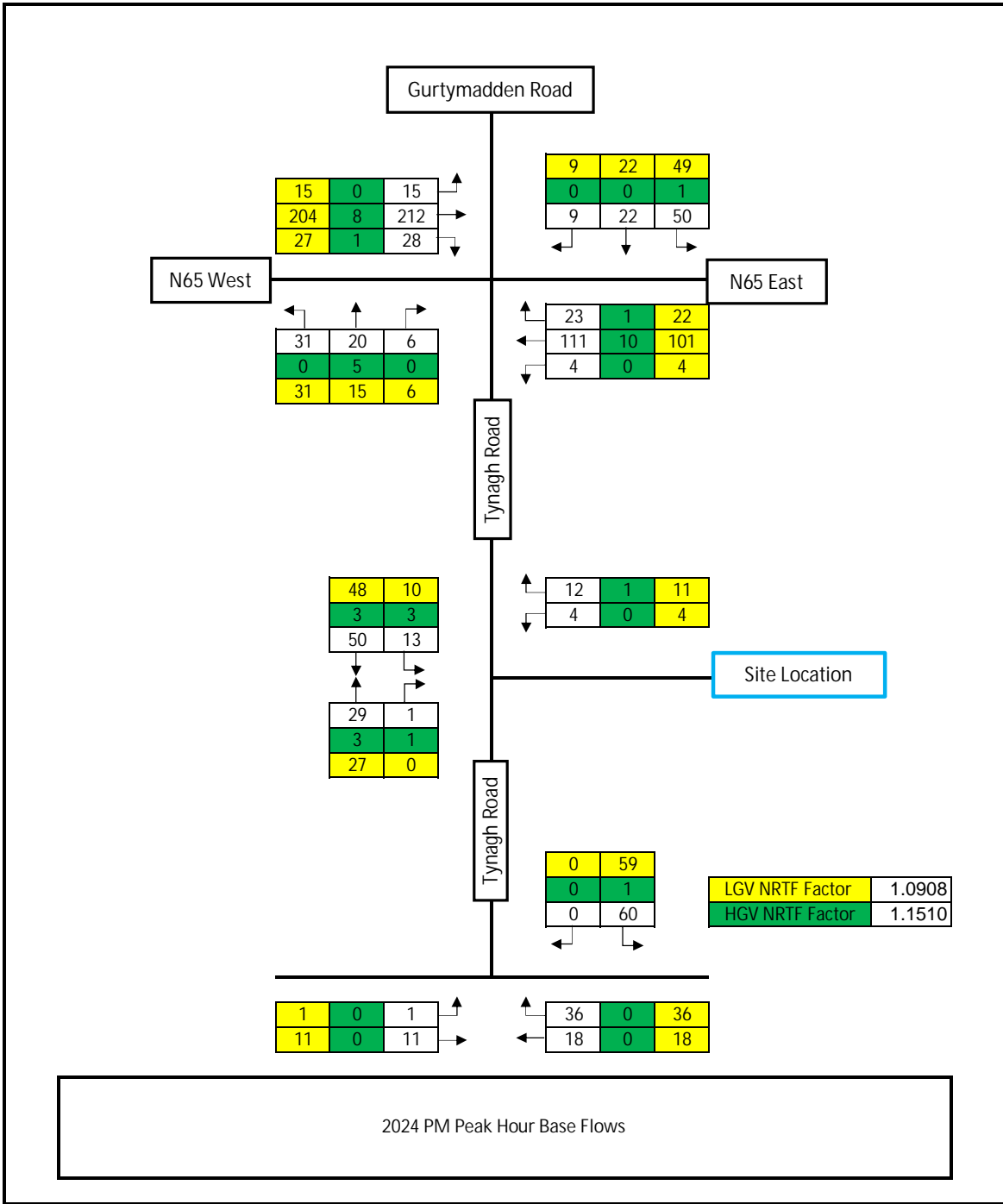

Gurty Madden Road

N65 West

N65 East

Tynagh Road

Tynagh Road

Site Location

LGV NRTF Factor	1.0908
HGV NRTF Factor	1.1510

15	0	15
204	8	212
27	1	28

9	22	49
0	0	1
9	22	50

31	20	6
0	5	0
31	15	6

23	1	22
111	10	101
4	0	4

48	10
3	3
50	13

12	1	11
4	0	4

29	1
3	1
27	0

0	59
0	1
0	60

1	0	1
11	0	11

36	0	36
18	0	18

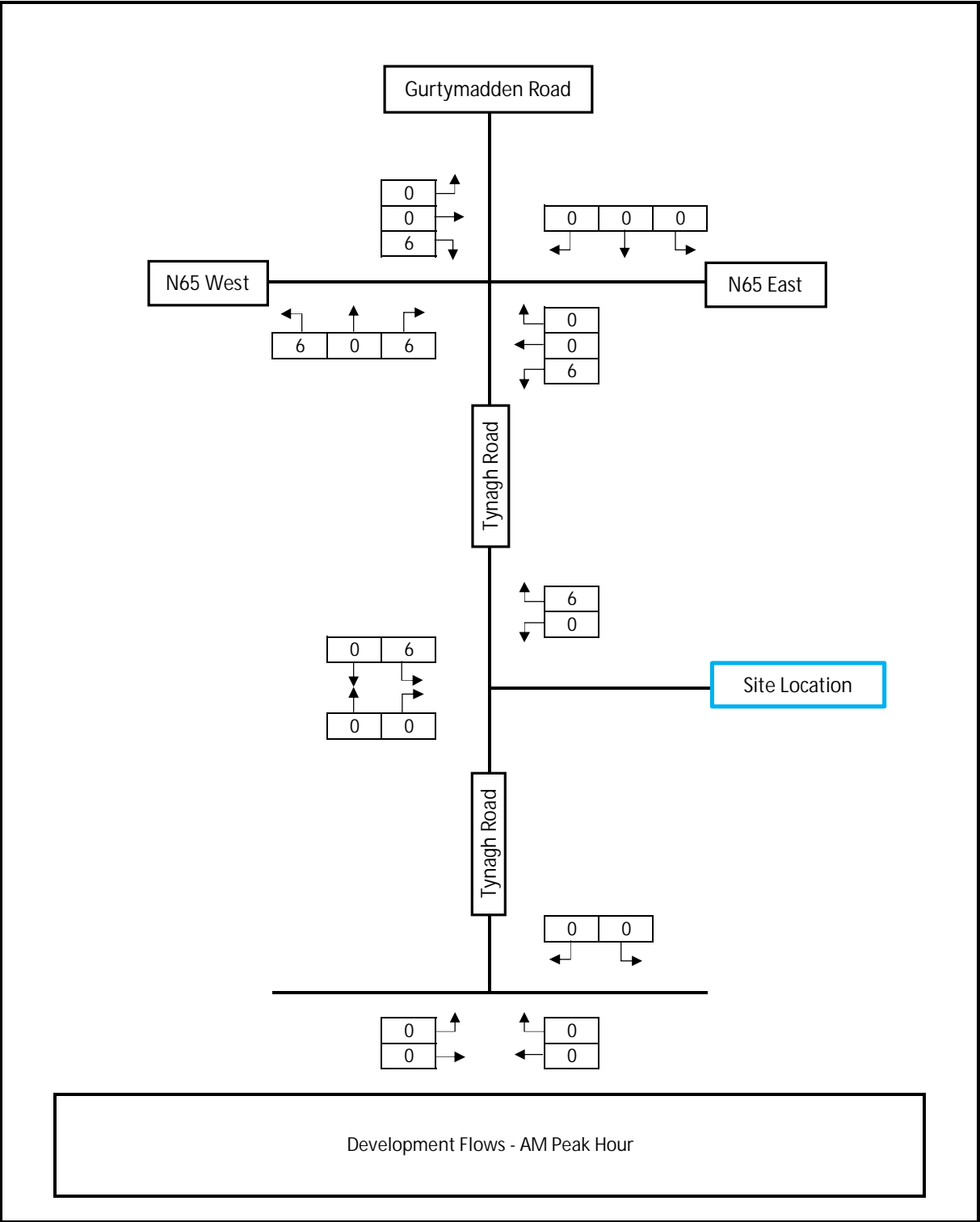

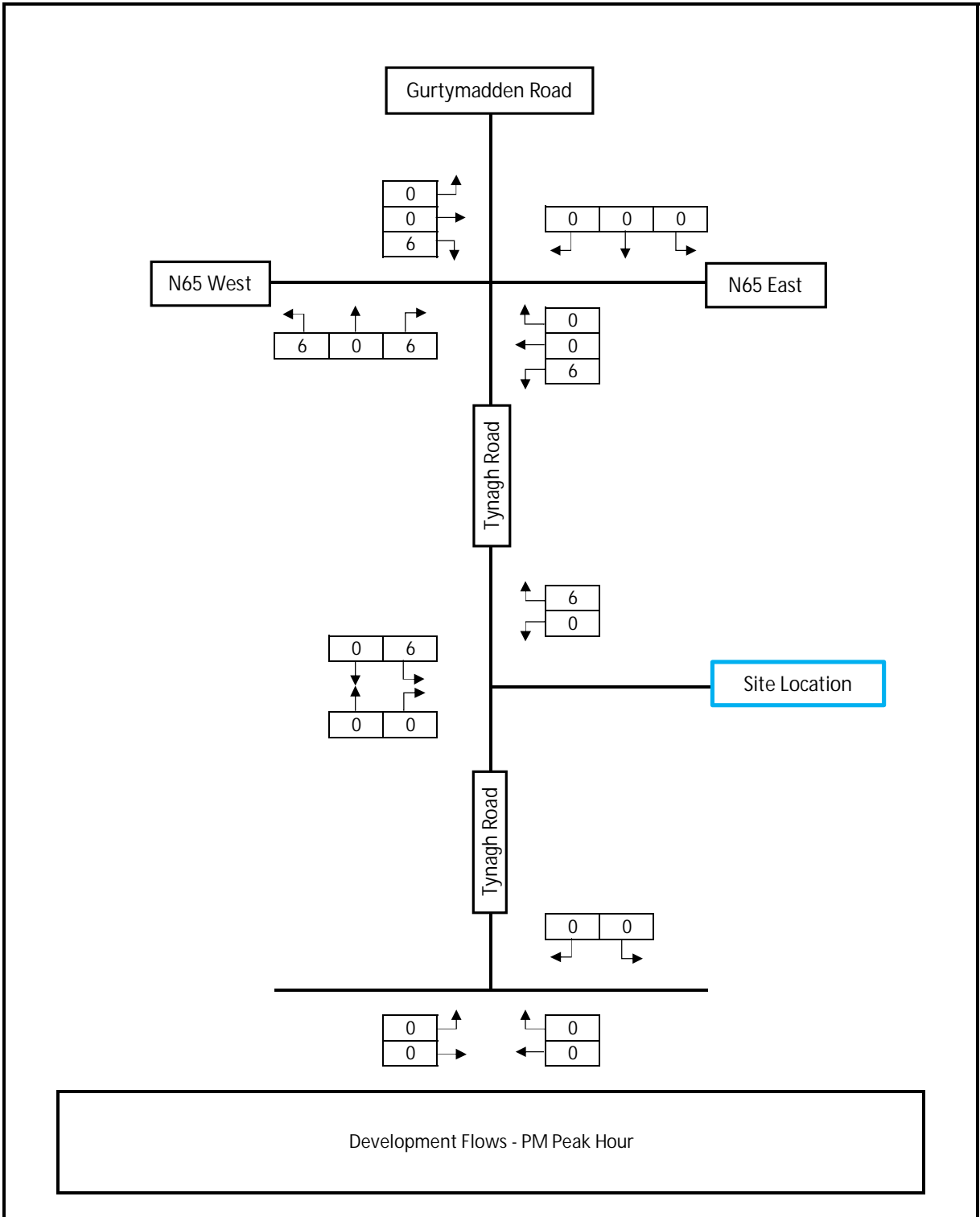

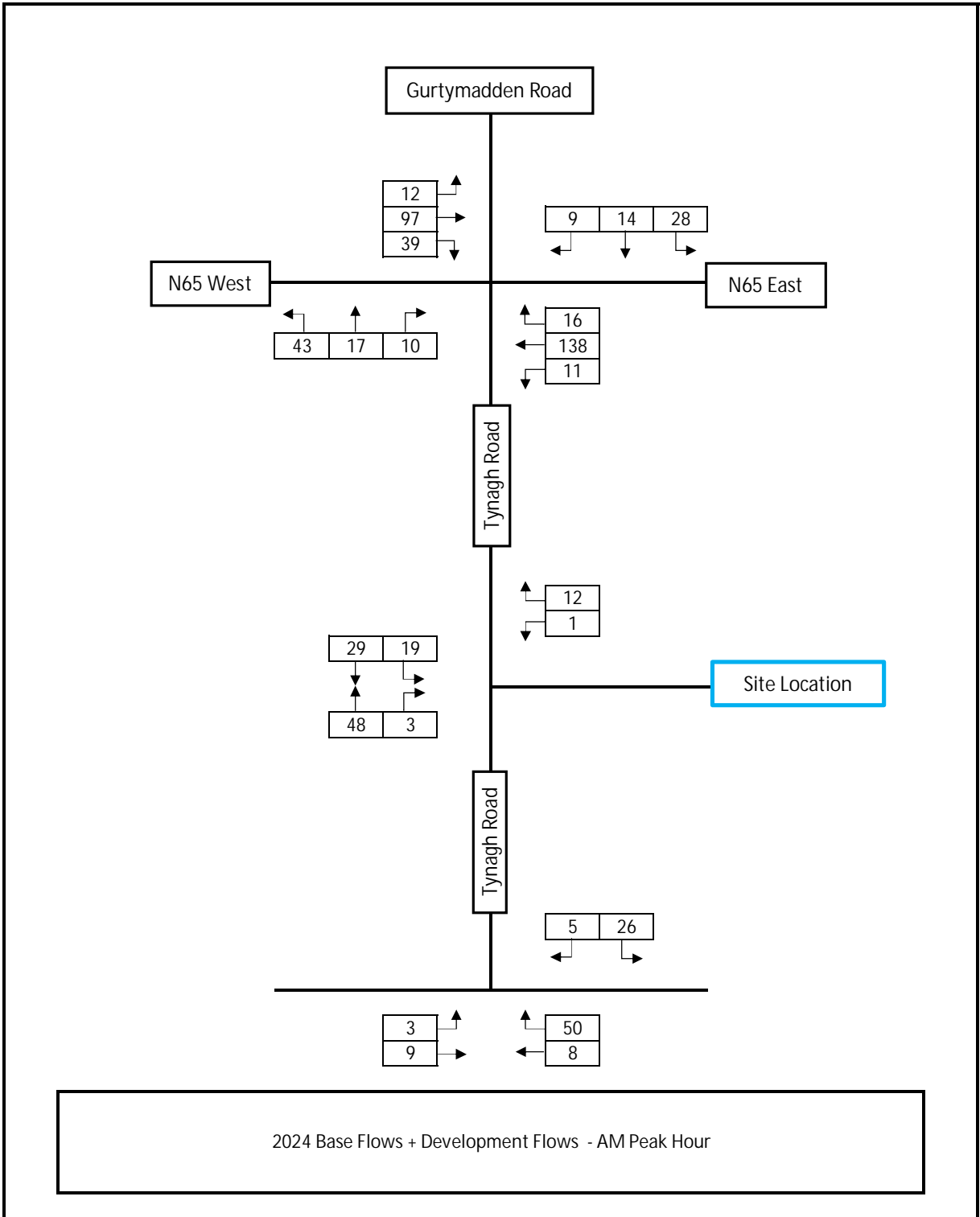

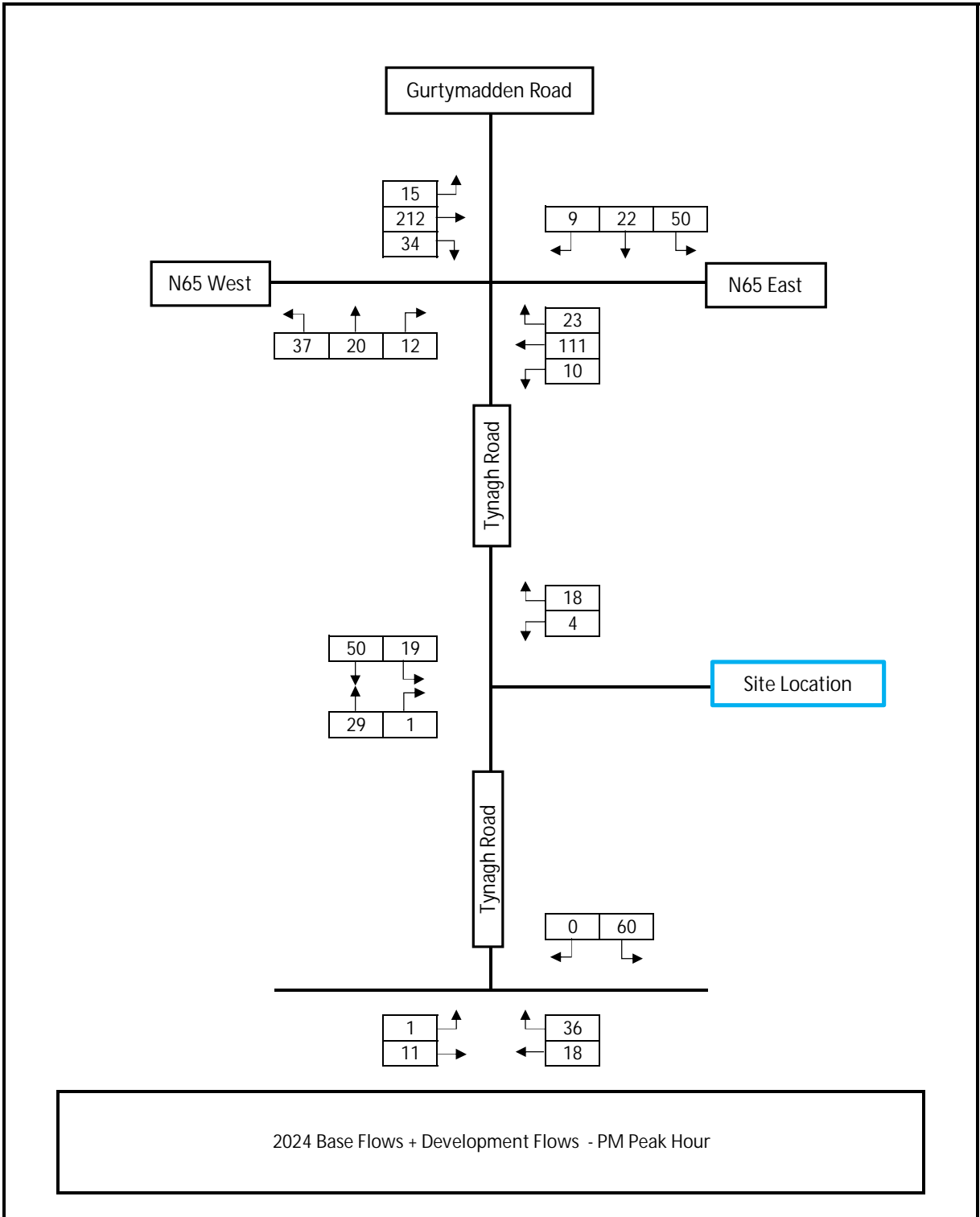

Gurty Madden Road

N65 West

N65 East

Tynagh Road

Tynagh Road

Site Location

15	↑
212	→
34	↓

9	←
22	↓
50	→

37	←
20	↑
12	→

23	↑
111	←
10	↓

50	↓
19	→

29	↑
1	→

18	↑
4	↓

0	←
60	→

1	↑
11	→

36	↑
18	←